

HEATHKIT[®] MANUAL

for the

SERIAL INTERFACE MODULE

Model H11-5

ASSEMBLY

595-2037-03

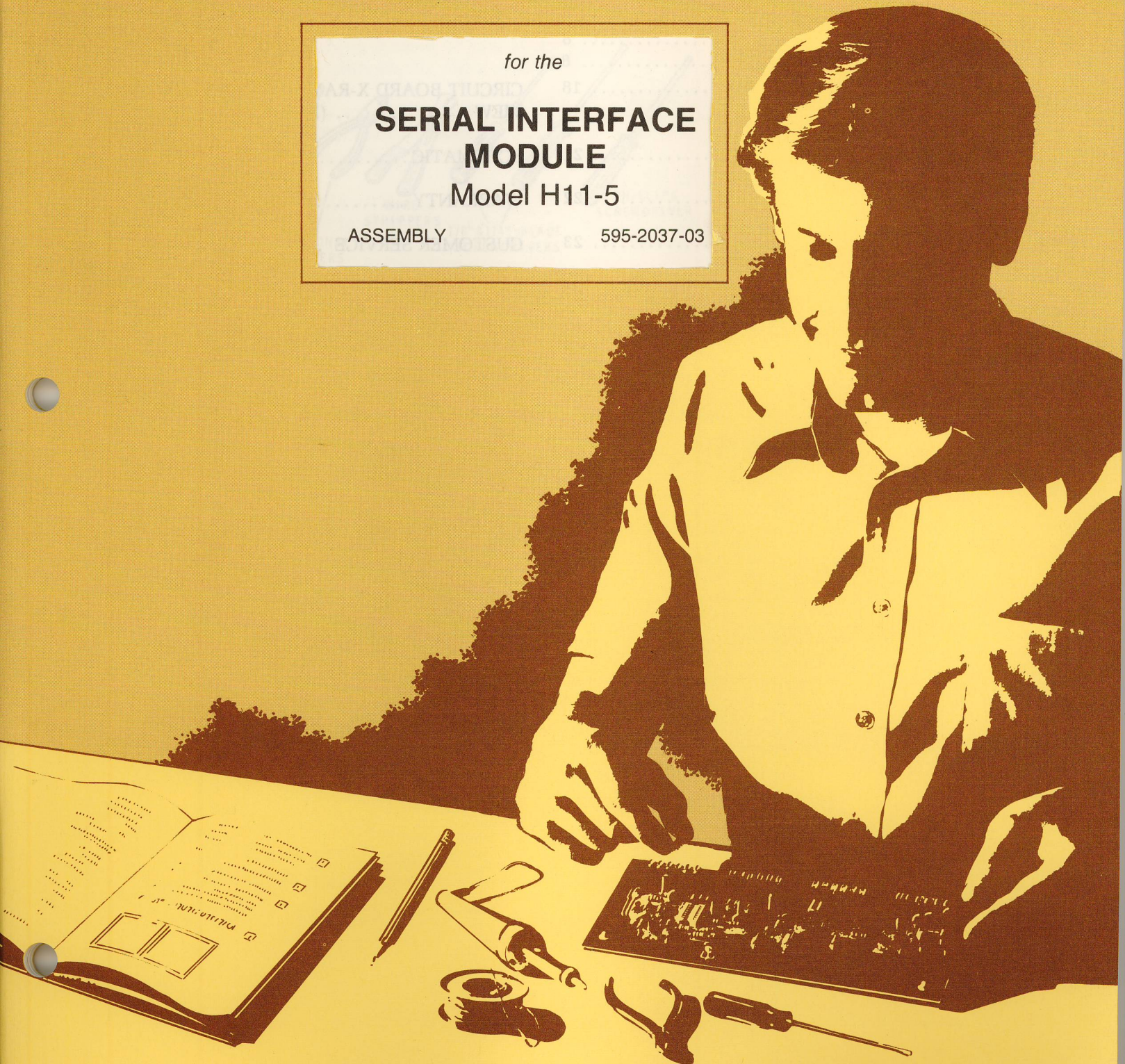

HEATH COMPANY • BENTON HARBOR, MICHIGAN

HEATH COMPANY PHONE DIRECTORY

The following telephone numbers are direct lines to the departments listed:

Kit orders and delivery information (616) 982-3411
Credit (616) 982-3561
Replacement Parts (616) 982-3571

Technical Assistance Phone Numbers

8:00 A.M. to 12 P.M. and 1:00 P.M. to 4:30 P.M., EST, Weekdays Only

R/C, Audio, and Electronic Organs (616) 982-3310
Amateur Radio (616) 982-3296
Test Equipment, Weather Instruments and
Home Clocks (616) 982-3313
Television (616) 982-3307
Aircraft, Marine, Security, Scanners, Automotive,
Appliances and General Products (616) 982-3496
Computers — Hardware (616) 982-3309
Computers — Software:
Operating Systems, Languages, Utilities (616) 982-3860
Application Programs (616) 982-3884
Heath Craft Wood Works (616) 982-3423



YOUR HEATHKIT 90-DAY LIMITED WARRANTY

Consumer Protection Plan for Heathkit Consumer Products

Welcome to the Heath family. We believe you will enjoy assembling your kit and will be pleased with its performance. Please read this Consumer Protection Plan carefully. It is a "LIMITED WARRANTY" as defined in the U.S. Consumer Product Warranty and Federal Trade Commission Improvement Act. This warranty gives you specific legal rights, and you may also have other rights which vary from state to state.

Heath's Responsibility

PARTS — Replacements for factory defective parts will be supplied free for 90 days from date of purchase. Replacement parts are warranted for the remaining portion of the original warranty period. You can obtain warranty parts direct from Heath Company by writing or telephoning us at (616) 982-3571. And we will pay shipping charges to get those parts to you . . . anywhere in the world.

SERVICE LABOR — For a period of 90 days from the date of purchase, any malfunction caused by defective parts or error in design will be corrected at no charge to you. You must deliver the unit at your expense to the Heath factory, any Heathkit Electronic Center (units of Veritechnology Electronics Corporation), or any of our authorized overseas distributors.

TECHNICAL CONSULTATION — You will receive free consultation on any problem you might encounter in the assembly or use of your Heathkit product. Just drop us a line or give us a call. Sorry, we cannot accept collect calls.

NOT COVERED — The correction of assembly errors, adjustments, calibration, and damage due to misuse, abuse, or negligence are not covered by the warranty. Use of corrosive solder and/or the unauthorized modification of the product or of any furnished component will void this warranty in its entirety. This warranty does not include reimbursement for inconvenience, loss of use, customer assembly, set-up time, or unauthorized service.

This warranty covers only Heath products and is not extended to other equipment or components that a customer uses in conjunction with our products.

SUCH REPAIR AND REPLACEMENT SHALL BE THE SOLE REMEDY OF THE CUSTOMER AND THERE SHALL BE NO LIABILITY ON THE PART OF HEATH FOR ANY SPECIAL, INDIRECT, INCIDENTAL OR CONSEQUENTIAL DAMAGES, INCLUDING BUT NOT LIMITED TO ANY LOSS OF BUSINESS OR PROFITS, WHETHER OR NOT FORSEEABLE.

Some states do not allow the exclusion or limitation of incidental or consequential damages, so the above limitation or exclusion may not apply to you.

Owner's Responsibility

EFFECTIVE WARRANTY DATE — Warranty begins on the date of first consumer purchase. You must supply a copy of your proof of purchase when you request warranty service or parts.

ASSEMBLY — Before seeking warranty service, you should complete the assembly by carefully following the manual instructions. Heathkit service agencies cannot complete assembly and adjustments that are customer's responsibility.

ACCESSORY EQUIPMENT — Performance malfunctions involving other non-Heath accessory equipment, (antennas, audio components, computer peripherals and software, etc.) are not covered by this warranty and are the owner's responsibility.

SHIPPING UNITS — Follow the packing instructions published in the assembly manuals. Damage due to inadequate packing cannot be repaired under warranty.

If you are not satisfied with our service (warranty or otherwise) or our products, write directly to our Director of Customer Service, Heath Company, Benton Harbor MI 49022. He will make certain your problems receive immediate, personal attention.

Heathkit® Manual

for the

SERIAL INTERFACE MODULE

Model H11-5

ASSEMBLY

595-2037-03

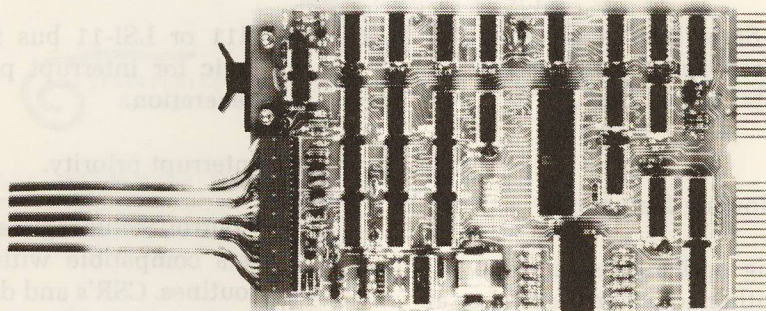

HEATH COMPANY
BENTON HARBOR, MICHIGAN 49022

Copyright © 1977
Heath Company
All Rights Reserved
Printed in the United States of America



TABLE OF CONTENTS

INTRODUCTION	2	GLOSSARY OF TERMS	26
ASSEMBLY NOTES	3	OPERATION	27
PARTS LIST	6	SEMICONDUCTOR IDENTIFICATION CHARTS	29
STEP-BY-STEP ASSEMBLY	8	CIRCUIT BOARD X-RAY VIEW	(Illustration Booklet, Page 8)
Circuit Board	8	SCHEMATIC	Fold-in
Cable and Configuration	18	WARRANTY	Inside front cover
INSTALLATION	21	CUSTOMER SERVICE	Inside rear cover
SPECIFICATIONS	22		
CIRCUIT DESCRIPTION	23		

INTRODUCTION

The Heath Model H11-5 Serial Interface Module connects a serially configured peripheral to either the Heath H11 bus or the DEC LSI-11 bus.

The Module has the following features:

- Option of using optically isolated 20 mA current loop (either active or passive) or an EIA interface.
- Selectable crystal-controlled baud rates: 50, 70, 110, 134.5, 150, 200, 300, 600, 1200, 1800, 2400, 4800, 9600, or an externally supplied rate.
- Selectable data word lengths.
- Selectable stop bits.

- H11 or LSI-11 bus interface and control logic for interrupt processing and vector generation.
- Interrupt priority.
- Control/Status register (CSR) and data registers compatible with PDP-11/03 software routines. CSR's and data buffer registers directly accessed by way of processor instructions.
- Plug, signal, and program compatible with PDP-11/03.

The modern digital design assures excellent accuracy and reliability. This, plus HEATH/DEC compatibility, makes the Module a valuable addition to your Computer System.

ASSEMBLY NOTES

TOOLS

You will need these tools to assemble your kit.

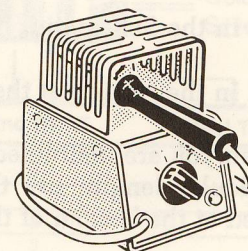
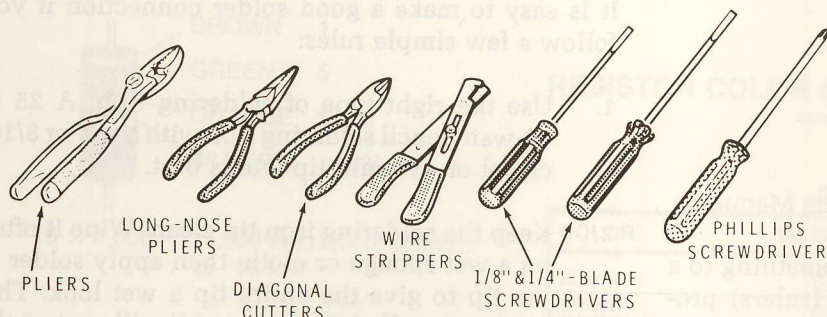

HEATHKIT
SOLDERING
IRON

OR

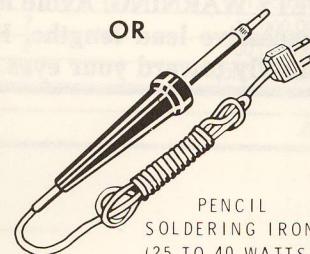

PENCIL
SOLDERING IRON
(25 TO 40 WATTS)

OTHER HELPFUL TOOLS

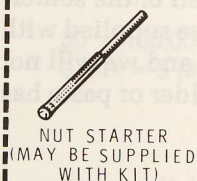

NUT STARTER
(MAY BE SUPPLIED
WITH KIT)

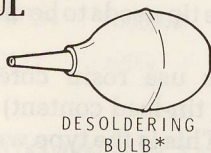

DESOLDERING
BULB*



DESOLDERING
BRAID*

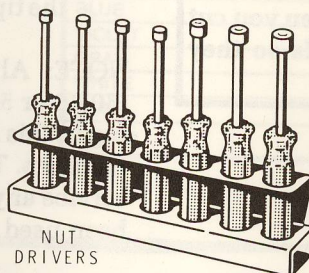

NUT
DRIVERS

*TO REMOVE SOLDER FROM CIRCUIT CONNECTIONS.

ASSEMBLY

1. Follow the instructions carefully. Read the entire step before you perform each operation.
2. The illustrations in the Manual are called Pictorials and Details. Pictorials show the overall operation for a group of assembly steps; Details generally illustrate a single step. When you are directed to refer to a certain Pictorial "for the following steps," continue using that Pictorial until you are referred to another Pictorial for another group of steps.
3. Most kits use a separate "Illustration Booklet" that contains illustrations (Pictorials, Details, etc.) that are too large for the Assembly Manual. Keep the "Illustration Booklet" with the Assembly Manual. The illustrations in it are arranged in Pictorial number sequence.
4. Position all parts as shown in the Pictorials.
5. Solder a part or a group of parts only when you are instructed to do so.

6. Each circuit part in an electronic kit has its own component number (R2, C4, etc.). Use these numbers when you want to identify the same part in the various sections of the Manual. These numbers, which are especially useful if a part has to be replaced, appear:
- In the Parts List,
 - At the beginning of each step where a component is installed,
 - In some illustrations,
 - In the Schematic,
 - In the section at the rear of the Manual.
7. When you are instructed to cut something to a particular length, use the scales (rulers) provided at the bottom of the Manual pages.

SAFETY WARNING: Avoid eye injury when you cut off excessive lead lengths. Hold the leads so they cannot fly toward your eyes.

SOLDERING

Soldering is one of the most important operations you will perform while assembling your kit. A good solder connection will form an electrical connection between two parts, such as a component lead and a circuit board foil. A bad solder connection could prevent an otherwise well-assembled kit from operating properly.

It is easy to make a good solder connection if you follow a few simple rules:

1. Use the right type of soldering iron. A 25 to 40-watt pencil soldering iron with a 1/8" or 3/16" chisel or pyramid tip works best.
2. Keep the soldering iron tip clean. Wipe it often on a wet sponge or cloth; then apply solder to the tip to give the entire tip a wet look. This process is called tinning, and it will protect the tip and enable you to make good connections. When solder tends to "ball" or does not stick to the tip, the tip needs to be cleaned and retinned.

NOTE: Always use rosin core, radio-type solder (60:40 or 50:50 tin-lead content) for all of the soldering in this kit. This is the type we have supplied with the parts. The Warranty will be void and we will not service any kit in which acid core solder or paste has been used.

PARTS

Resistors will be called out by their resistance value in Ω (ohms), $k\Omega$ (kilohms), or $M\Omega$ (megohms). Certain types of resistors will have the value printed on the body, while others will be identified by a color code. The colors of the bands and the value will be given in the steps, therefore the following color code is given for information only.

EXAMPLES:

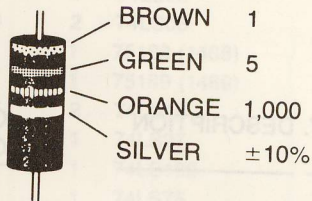

$15 \times 1,000 = 15,000 \Omega$ (15,000 OHMS),
or "15 $k\Omega$ "

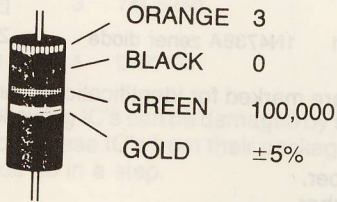

$30 \times 100,000 = 3,000,000 \Omega$ (or 3 $M\Omega$)
3 $M\Omega = 3$ MEGOHMS

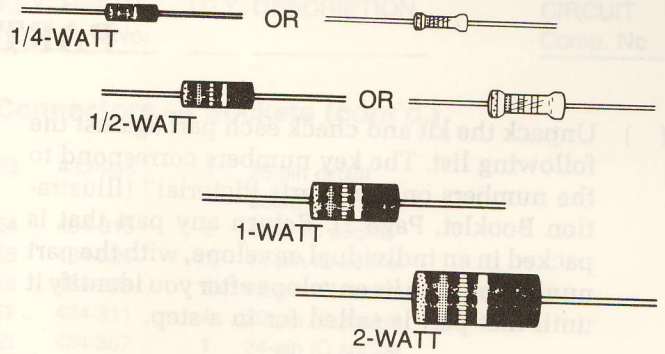

RESISTOR COLOR CODE

TOLERANCE
Gold 5%
Silver 10%

COLOR	1st DIGIT	2nd DIGIT	MULTIPLY BY
BLACK	0	0	1
BROWN	1	1	10
RED	2	2	100
ORANGE	3	3	1,000
YELLOW	4	4	10,000
GREEN	5	5	100,000
BLUE	6	6	1,000,000
VIOLET	7	7	10,000,000
GRAY	8	8	100,000,000
WHITE	9	9	1,000,000,000
GOLD			.1
SILVER			.01

Capacitors will be called out by their capacitance value in μF (microfarads) or pF (picofarads) and type: ceramic, Mylar*, electrolytic, etc. Some capacitors may have their value printed in the following manner:

EXAMPLES:

$151K = 15 \times 10 = 150 \text{ pF}$
 $759 = 75 \times 0.1 = 7.5 \text{ pF}$

NOTE: The letter "R" may be used at times to signify a decimal point; as in: 2R2 = 2.2 (pF or μF).

First digit of capacitor's value: 1

Second digit of capacitor's value: 5

Multiplier: Multiply the first & second digits by the proper value from the Multiplier Chart.

To find the tolerance of the capacitor, look up this letter in the Tolerance columns.



MULTIPLIER		TOLERANCE OF CAPACITOR		
FOR THE NUMBER:	MULTIPLY BY:	10pF OR LESS	LETTER	OVER 10pF
0	1	$\pm 0.1 \text{ pF}$	B	
1	10	$\pm 0.25 \text{ pF}$	C	
2	100	$\pm 0.5 \text{ pF}$	D	
3	1000	$\pm 1.0 \text{ pF}$	F	$\pm 1\%$
4	10,000	$\pm 2.0 \text{ pF}$	G	$\pm 2\%$
5	100,000		H	$\pm 3\%$
			J	$\pm 5\%$
8	0.01		K	$\pm 10\%$
9	0.1		M	$\pm 20\%$

*DuPont Registered Trademark

PARTS LIST

- () Unpack the kit and check each part against the following list. The key numbers correspond to the numbers on the "Parts Pictorial" (Illustration Booklet, Page 1). Return any part that is packed in an individual envelope, with the part number on it, to its envelope after you identify it until that part is called for in a step.

To order a replacement part, always include the PART NUMBER. Use the Parts Order Form furnished with this kit. If one is not available, see "Replacement Parts" inside the rear cover of your Digital Computer Assembly Manual. For prices, refer to the separate "Heath Parts Price List."

KEY No.	HEATH Part No.	QTY.	DESCRIPTION	CIRCUIT Comp. No.
---------	----------------	------	-------------	-------------------

RESISTORS

NOTE: The following resistors are 1/4-watt and have a tolerance of 5% (gold fourth band) unless otherwise noted. The resistors may be packed in more than one envelope.

A1	1-58-12	2	47 Ω (yellow-violet-black)	R1, R2
A1	1-103-12	2	150 Ω (brown-green-brown)	R3, R8
A1	1-62-12	1	220 Ω (red-red-brown)	R5
A1	1-121-12	1	300 Ω (orange-black-brown)	R33
A1	1-92-12	1	330 Ω (orange-orange-brown)	R34
A1	1-67-12	1	680 Ω (blue-gray-brown)	R35
A1	1-68-12	2	820 Ω (gray-red-brown)	R4, R12
A1	1-69-12	3	1000 Ω (brown-black-red)	R22, R24, R41
A1	1-97-12	1	2400 Ω (red-yellow-red)	R6
A1	1-80-12	20	10 k Ω (brown-black-orange)	R14-R19, R21, R23, R25-R29, R31, R32, R36-R40
A1	1-156-12	1	68 k Ω (blue-gray-orange)	R7
A1	1-157-12	1	10 M Ω (brown-black-blue)	R9
A2	1-151	1	330 Ω , 1/2-watt (orange-orange-brown)	R11

CAPACITORS

B1	21-155	2	33 pF ceramic	C5, C6
B1	21-722	4	330 pF ceramic	C1, C2, C3, C4
B1	21-140	1	.001 μ F (1000 pF) ceramic	C19
B1	21-27	1	.005 μ F ceramic	C12
B2	25-221	10	2.2 μ F tantalum	C7, C8, C9, C11, C13, C14, C15, C16, C17, C18

KEY No.	HEATH Part No.	QTY.	DESCRIPTION	CIRCUIT Comp. No.
---------	----------------	------	-------------	-------------------

DIODES — TRANSISTORS

C1	56-56	5	1N4149 diode	D1, D2, D3, D5, D6
C1	56-621	1	1N4738A zener diode	ZD4

NOTE: Transistors are marked for identification in one of the following four ways:

1. Part number.
2. Type number.
3. Part number and type number.
4. Part number with a type number other than the one listed.

C2	417-821	3	MPSA06 transistor	Q1, Q4, Q5
C2	417-865	3	MPSA55 transistor	Q2, Q6, Q7
C2	417-897	1	30 V, 1.5 mA FET	Q3

INTEGRATED CIRCUITS (IC s)

IMPORTANT: If any components are missing from the sealed IC package return the UNOPENED package for replacement. Claims for missing IC s will not be honored if the package has been opened.

If you locate damaged or defective IC s, order individual replacements. Be sure to follow the standard instructions on the "Parts Order Form" and on the inside rear cover of the Manual. Save defective or damaged components for return instructions.

NOTE: Integrated circuits (IC s) are marked for identification in one of the following four ways:

1. Part number.
2. Type number (this refers only to the numbers; the letters may vary).
3. Part number and type number.
4. Part number with a type number other than the one listed.



KEY No.	HEATH Part No.	QTY.	DESCRIPTION	CIRCUIT Comp. No.	KEY No.	HEATH Part No.	QTY.	DESCRIPTION	CIRCUIT Comp. No.
---------	----------------	------	-------------	-------------------	---------	----------------	------	-------------	-------------------

Integrated Circuit (cont'd.)

D1	443-808	2	4N26	IC28, IC29
D2	443-77	1	7438	IC9
D2	443-728	2	74LS00	IC10, IC16
D2	443-730	4	74LS74	IC13, IC15, IC17, IC22
D2	443-779	1	74LS02	IC21
D2	443-780	2	74LS08	IC11, IC26
D2	443-794	1	75188 (1488)	IC24
D2	443-795	1	75189 (1489)	IC23
D2	443-797	2	74LS10	IC14, IC18
D2	443-800	1	74LS27	IC12
D2	443-801	1	74LS196	IC25
D3	443-781	1	74LS75	IC19
D3	443-799	1	74LS157	IC6
D3	443-802	2	74LS257	IC7, IC8
D4	443-753	1	74LS240	IC4
D4	443-754	3	74LS240	IC1, IC2, IC3
D5	443-796	1	DM8130	IC5

NOTE: The following IC's can be damaged by static electricity. Do NOT remove these IC's from their packages until you are instructed to do so in a step.

D3	443-793	1	4702	IC27
D6	443-761	1	IM6402	IC20

CONNECTORS — SOCKETS

E1	432-704	1	24-pin plug
E2	432-855	26	Female connector pin (two extra)

Connectors — Sockets (cont'd.)

E3	432-965	1	25-pin circuit board connector
E4	434-315	2	6-pin IC socket
E5	434-298	16	14-pin IC socket
E6	434-299	5	16-pin IC socket
E7	434-311	4	20-pin IC socket
E8	434-307	1	24-pin IC socket
E9	434-253	1	40-pin IC socket

HARDWARE

F1	250-52	2	4-40 × 1/4" screw
F2	252-2	2	4-40 nut
F3	254-9	2	#4 lockwasher

MISCELLANEOUS

	85-2091-2	1	Serial interface circuit board	
G1	266-949	1	Circuit board puller	
	134-1020	1	25-wire cable assembly	
	344-94	3'	Yellow wire	
	347-39	72'	5-wire cable	
G2	404-597	1	Oscillator crystal	K1
G3	390-1397	1	Serial I/O label	
G4	390-1706	1	Printer label	
G5	390-1707	1	Console label	
G6	391-34	1	Blue and white label	
	490-185	1	Package of solder braid	
G7	490-189	1	IC puller	
	597-260	1	Parts Order Form	
		1	Assembly Manual (See Page 1 for part number.)	
			Solder	

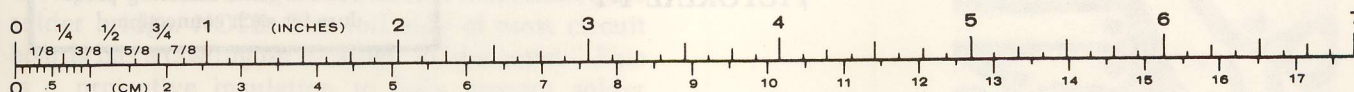

STEP-BY-STEP ASSEMBLY

CIRCUIT BOARD

START

In the following steps, you will be given detailed instructions on how to install and solder the first part on the circuit board. Read and perform each step carefully. Then use the same procedure whenever you install parts on a circuit board.

- () Position the circuit board as shown with the component side up.

- () R11: Hold a 330 Ω , 1/2-watt (orange-orange-brown) resistor by the body as shown and bend the leads straight down.

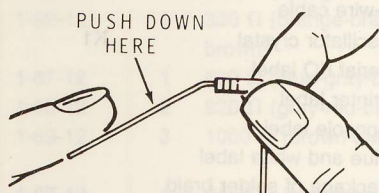

- () Push the leads through the holes at the indicated location on the circuit board. The end with color bands may be positioned either way.

- () Press the resistor against the circuit board. Then bend the leads outward slightly to hold the resistor in place.

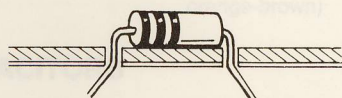

IDENTIFICATION DRAWING

PART NUMBER

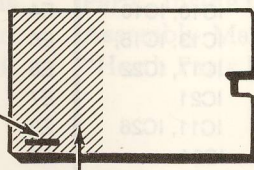

The parts installed in this Pictorial are in this area of the circuit board.

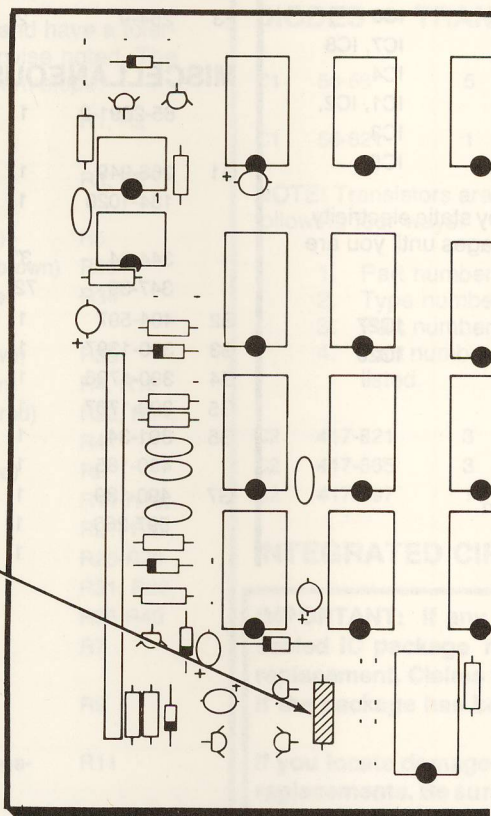

PICTORIAL 1-1

CONTINUE

- () Solder the resistor leads to the circuit board as follows:

1. Push the soldering iron tip against both the lead and the circuit board foil. Heat **both** for two or three seconds.

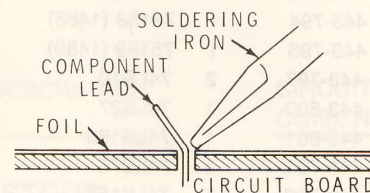

2. Then apply solder to the other side of the connection. **IMPORTANT:** Let the heated lead and the circuit board foil melt the solder.

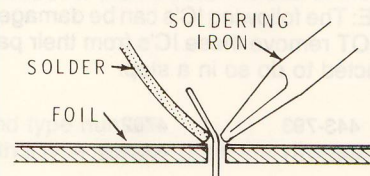

3. As the solder begins to melt, allow it to flow around the connection. Then remove the solder and the iron and let the connection cool.

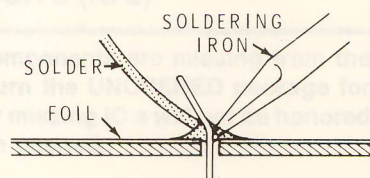

- () Cut off the excess lead lengths close to the connection. **WARNING:** Clip the leads so the ends will not fly toward your eyes.

- () Check each connection. Compare it to the illustrations on Page 9. After you have checked the solder connections, proceed with the assembly on Page 10. Use the same soldering procedure for each connection.

A GOOD SOLDER CONNECTION

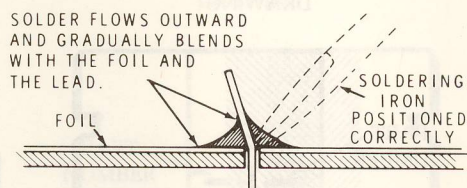

When you heat the lead and the circuit board foil at the same time, the solder will flow evenly onto the lead and the foil. The solder will make a good electrical connection between the lead and the foil.

POOR SOLDER CONNECTIONS

SOLDER DOES NOT FLOW ONTO LEAD. A DARK ROSIN BEAD SURROUNDS AND INSULATES THE LEAD FROM THE CONNECTION.

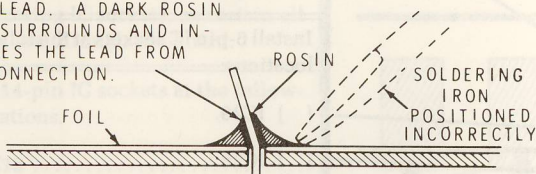

When the lead is not heated sufficiently, the solder will not flow onto the lead as shown above. To correct, reheat the connection and, if necessary, apply a small amount of additional solder to obtain a good connection.

SOLDER APPEARS TO FLOW INWARD AND SET ON TOP OF THE FOIL.

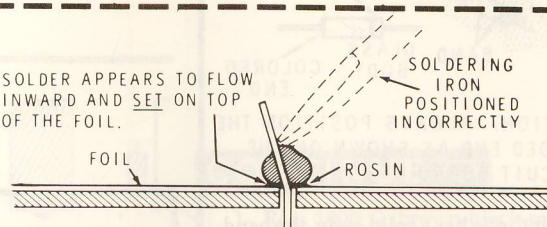

When the foil is not heated sufficiently the solder will blob on the circuit board as shown above. To correct, reheat the connection and, if necessary, apply a small amount of additional solder to obtain a good connection.

SOLDER BRIDGES

A solder bridge between two adjacent foils is shown in photograph A. Photograph B shows how the connection should appear. A solder bridge may occur if you accidentally touch an adjacent previously soldered connection, if you use too much solder, or if you "drag" the soldering iron across other foils as you remove it from the connection. A good rule to follow is: always take a good look at the foil area around each lead before you solder it. Then, when you solder the connection, make sure the solder remains in this area and does not bridge to another foil. This is especially important when the foils are small and close together. NOTE: It is alright for solder to bridge two connections on the same foil.

Use only enough solder to make a good connection, and lift the soldering iron straight up from the circuit board. If a solder bridge should develop, turn the circuit board foil-side-down and heat the solder between connections. The excess solder will run onto the tip of the soldering iron, and this will remove the solder bridge. NOTE: The foil side of most circuit boards has a coating on it called "solder resist." This is a protective insulation to help prevent solder bridges.

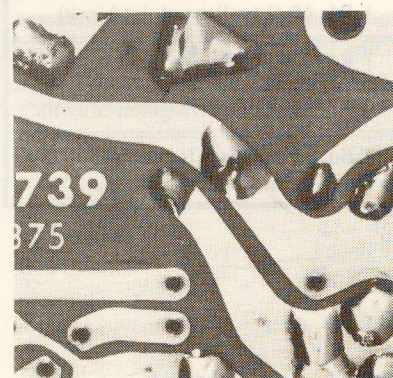
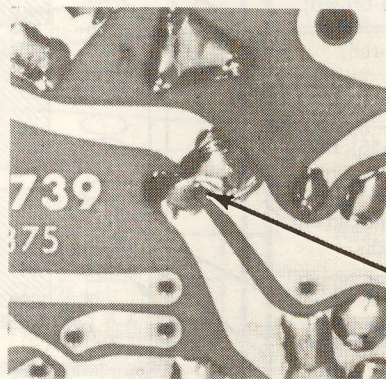

START

NOTE: Make sure you have installed the resistor in Pictorial 1-1.

IMPORTANT: THE BANDED END OF DIODES CAN BE MARKED IN A NUMBER OF WAYS.

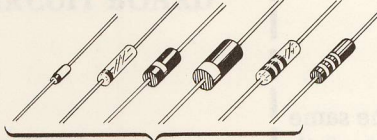

BANDED END

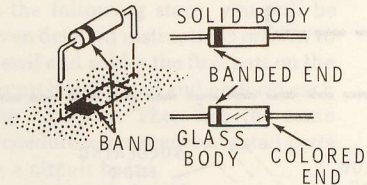

CAUTION: ALWAYS POSITION THE BANDED END AS SHOWN ON THE CIRCUIT BOARD.

If your diode has a solid body, the band is clearly defined. If your diode has a glass body, do not mistake the colored end inside the diode for the banded end. Look for a band painted on the outside of the glass.

- () D2: 1N4149 diode (#56-56).
- () R7: 68 k Ω (blue-gray-orange).
- () R8: 150 Ω (brown-green-brown).
- () R6: 2400 Ω (red-yellow-red).
- () R5: 220 Ω (red-red-brown).
- () D1: 1N4149 diode (#56-56). Position the banded end as shown.
- () Solder the leads to the foil and cut off the excess lead lengths.
- () R2: 47 Ω (yellow-violet-black).
- () D3: 1N4149 diode (#56-56). Position the banded end as shown.
- () R1: 47 Ω (yellow-violet-black).
- () R4: 820 Ω (gray-red-brown).
- () R3: 150 Ω (brown-green-brown).
- () Solder the leads to the foil and cut off the excess lead lengths.

IDENTIFICATION DRAWING

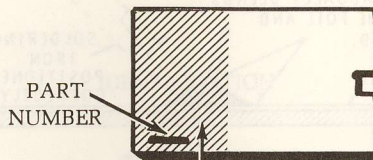

The parts installed in this Pictorial are in this area of the circuit board.

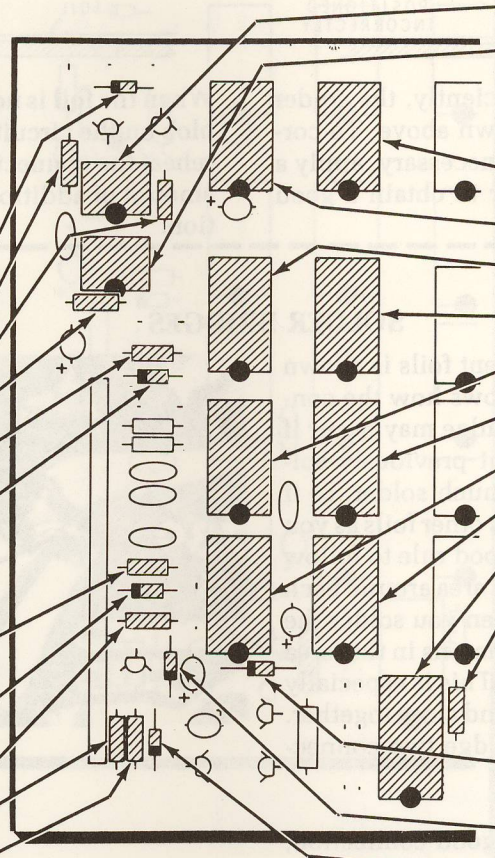

PICTORIAL 1-2

CONTINUE

NOTE: In the following steps, before you mount each IC socket, make sure all the socket pins are straight. Then, as you mount the socket, make sure all its pins are through the foil. First solder one pin at each end of the socket to the foil and again make sure all the pins are through the foil. Then solder the remaining pins to the foil.

Install 6-pin IC sockets at the following locations:

- () IC29.
- () IC28.

Install 14-pin sockets at the following locations:

- () IC14.
- () IC15.
- () IC16.
- () IC17.
- () IC23.
- () IC22.
- () IC24.
- () IC25.

() Install a 16-pin IC socket at IC27.

- () R9: 10 M Ω (brown-black-blue).

NOTE: As you mount diodes in the following steps, position the banded ends as shown.

- () ZD4: 1N4738A zener diode (#56-621).
- () D5: 1N4149 diode (#56-56).
- () D6: 1N4149 diode (#56-56).
- () Solder the leads to the foil and cut off the excess lead lengths.

IDENTIFICATION
DRAWING

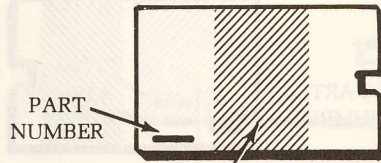

The parts installed in this Pictorial are in this area of the circuit board.

START ↘

- () R33: 300 Ω (orange-black-brown). Solder the leads to the foil and cut off the excess lead lengths.

NOTE: Before you solder the pins of the following IC sockets, be certain all its pins are through the board.

Install 14-pin IC sockets at the following locations.

- () IC13
- () IC12
- () IC11
- () IC18
- () IC21
- () IC26

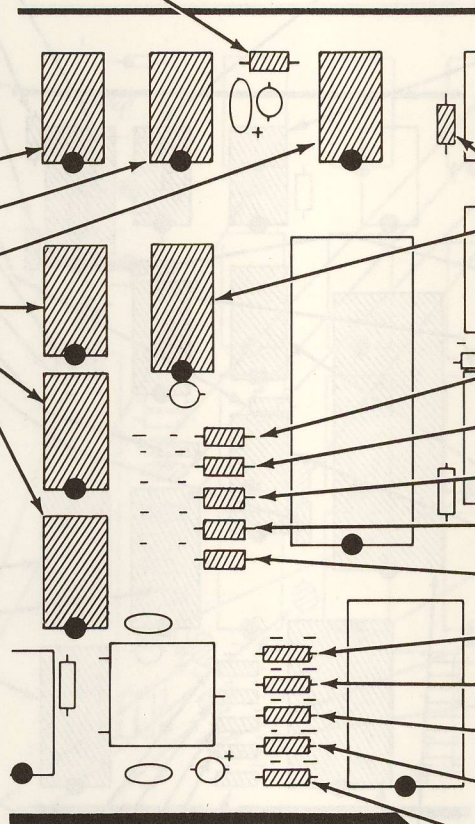

CONTINUE ↙

- () R41: 1000 Ω (brown-black-red).

- () Install a 16-pin IC socket at IC19.

Install 10 kΩ (brown-black-orange) resistors in the next ten steps.

- () R36.
- () R37.
- () R38.
- () R39.
- () R40.
- () R32.
- () R29.
- () R28.
- () R27.
- () R31.

- () Solder the leads to the foil and cut off the excess lead lengths.

PICTORIAL 1-3

IDENTIFICATION
DRAWING

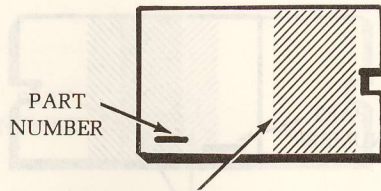

The parts installed in this area of the circuit board.

START ↘

Install 14-pin IC sockets at the following locations:

- () IC9
- () IC10

NOTE: When you cut off resistor leads in the following steps, set them aside for use later. You will use them as jumpers when you configure the circuit board.

- () R12: 820 Ω (gray-red-brown). Solder the leads to the foil and cut off the excess lead lengths.

Install 16-pin IC sockets at the following locations:

- () IC7
- () IC8
- () IC6

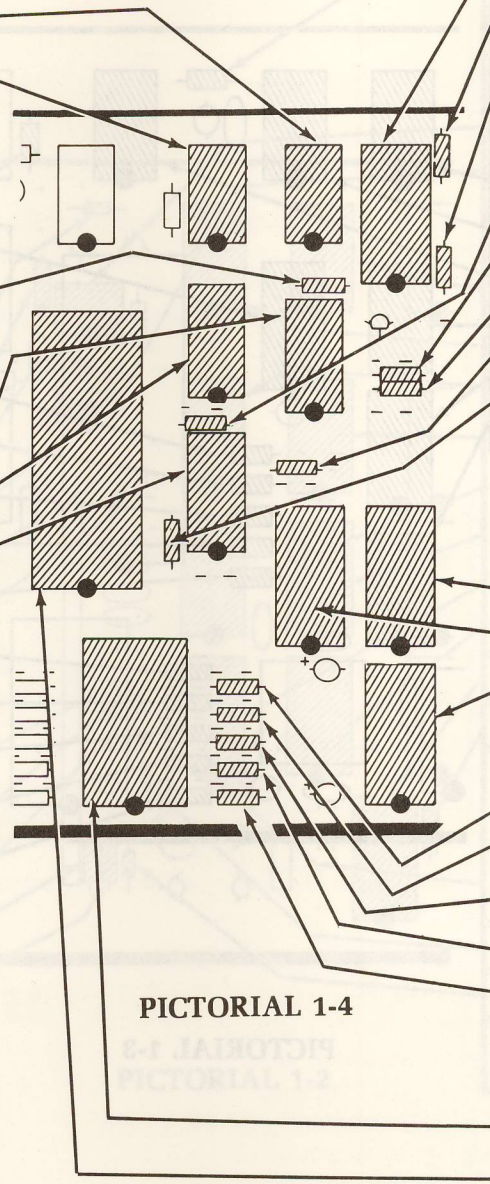

PICTORIAL 1-4

CONTINUE ↘

- () Install a 20-pin IC socket at IC2.
- () R34: 330 Ω (orange-orange-brown).
- () R35: 680 Ω (blue-gray-brown).

Install 10 k Ω (brown-black-orange) resistors in the next five steps.

- () R17.
- () R14.
- () R15.
- () R16.
- () R18.

Solder the leads to the foil and cut off the excess lead lengths.

Install 20-pin IC sockets at the following locations:

- () IC4.
- () IC3.
- () IC1.

Install 10 k Ω (brown-black-orange) resistors in the next five steps.

- () R26.
- () R25.
- () R23.
- () R21.
- () R19.

Solder the leads to the foil and cut off the excess lead lengths.

- () Install a 24-pin IC socket at IC5.
- () Install a 40-pin IC socket at IC20.

IDENTIFICATION
DRAWING

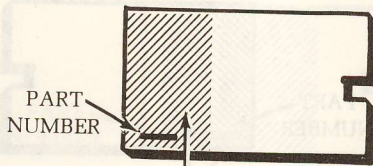

The parts installed in this Pictorial are in this area of the circuit board.

START →

NOTE: When you install transistors, line up the flat on the transistor with the outline of the flat on the circuit board. Then insert the E, B, and C leads of the transistor into the corresponding E, B, and C holes in the circuit board. Position the transistor 1/8" above the foil and solder the leads to the foil and cut off the excess lead lengths.

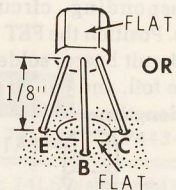

() Q2: MPSA55 transistor (#417-865).

NOTE: Tantalum capacitors may be marked two ways as shown. When you install the following capacitor, be sure to insert the lead marked with a positive (+) sign or color dot in the positive (+) marked hole on the circuit board.

MAY BE MARKED WITH POSITIVE SIGN(+) OR COLOR DOT

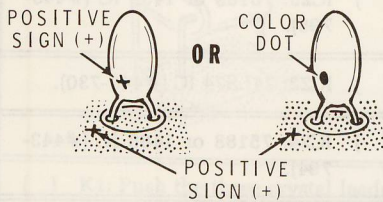

() C16: 2.2 μ F tantalum.

() C9: 2.2 μ F tantalum.

Install three 2.2 μ F tantalum capacitors. Position the positive (+) marks as shown.

- () C8
- () C14
- () C7

CONTINUE →

NOTE: When you install ceramic capacitors in this kit, remove any excess coating from the leads. Use long-nose pliers to remove this coating.

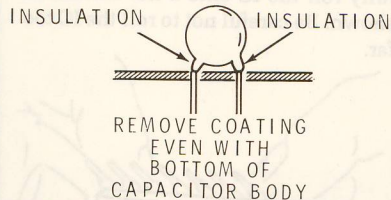

Install 330 pF ceramic capacitors in the next four steps.

- () C4.
- () C3.
- () C1.
- () C2.

() Solder the leads to the foil and cut off the excess lead lengths.

NOTE: As you mount transistors in the following steps, be sure to match the flat on each transistor with the flat screened on the circuit board.

- () Q7: MPSA55 transistor (#417-865).
- () Q5: MPSA06 transistor (#417-821).
- () Q6: MPSA55 transistor (#417-865).
- () Q4: MPSA06 transistor (#417-821).

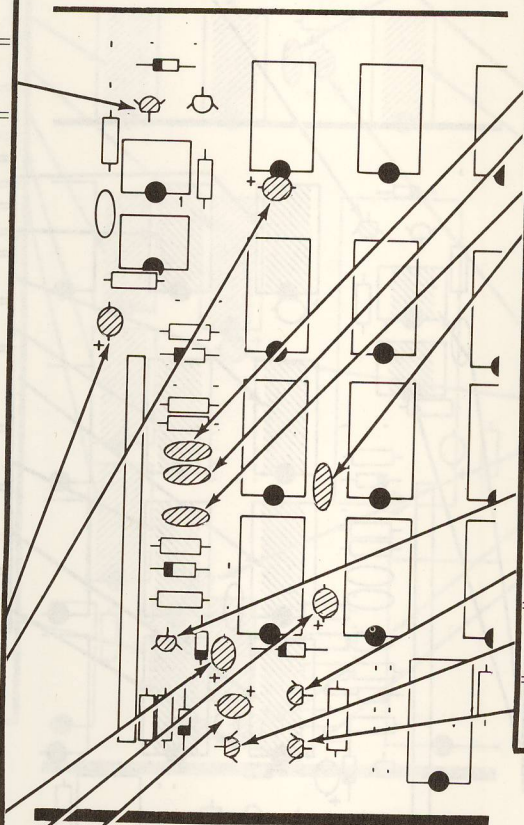

PICTORIAL 1-5

IDENTIFICATION
DRAWING

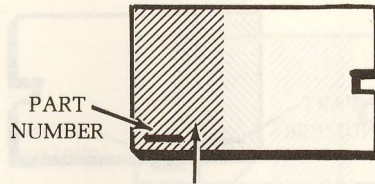

The parts installed in this Pictorial are in this area of the circuit board.

START →

Before you install IC's in the following steps, the IC pins must be made perpendicular to the IC body. To do this, grasp the IC between the thumbs and index fingers of both hands, then carefully roll the IC onto a flat surface as shown. Be careful not to roll the IC too far.

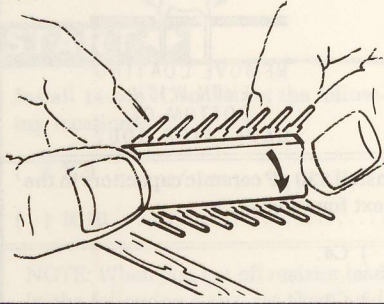

Install IC's as follows: Identify the pin 1 of the IC, then match the pin 1 end of the IC with the marked end of the IC outline on the circuit board and in the Pictorial. Then carefully push the IC down into its socket. (Also see Detail 1-6A on Page 2 of the "Illustration Booklet" as you install IC's.)

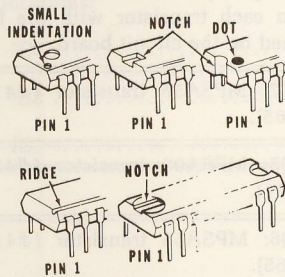

- () IC29: 4N26 IC (#443-808).
- () IC28: 4N26 IC (#443-808).

CONTINUE →

- () Q3: 30V, 1.5 mA FET (#417-897). Line up the flat on the FET with the outline of the flat on the circuit board. Then insert the D, S, and G leads of the FET into the corresponding circuit board holes. Position the FET 1/8" above the circuit board, solder its leads to the foil, and cut off the excess lead lengths.

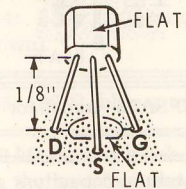

- () IC15: 74LS74 IC (#443-730).
- () IC14: 74LS10 IC (#443-797).
- () IC16: 74LS00 IC (#443-728).
- () IC17: 74LS74 IC (#443-730).
- () IC23: 75189 or 1489 IC (#443-795).
- () IC22: 74LS74 IC (#443-730).
- () IC24: 75188 or 1488 IC (#443-794).
- () IC25: 74LS196 IC (#443-801).

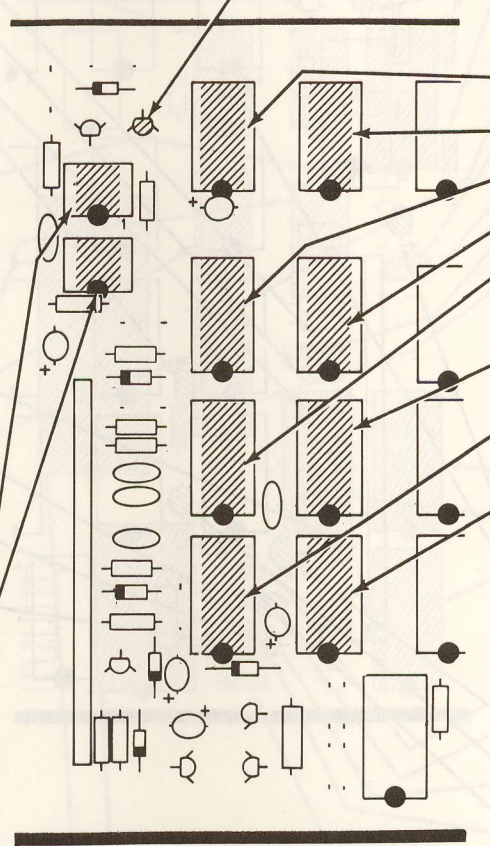

PICTORIAL 1-6

IDENTIFICATION
DRAWING

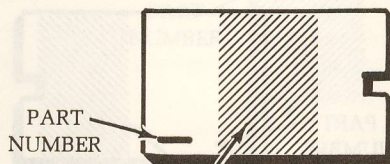

The parts installed in this Pictorial are in this area of the circuit board.

START ▾

- () IC12: 74LS27 IC (#443-800).
- () IC13: 74LS74 IC (#443-730).
- () IC19: 74LS75 IC (#443-781).
- () IC18: 74LS10 IC (#443-797).
- () IC21: 74LS02 IC (#443-779).
- () IC26: 74LS08 IC (#443-780).
- () Form the leads of the oscillator crystal 90-degrees to the crystal case as shown.

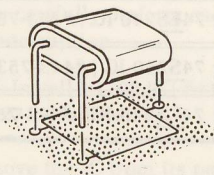

- () K1: Push the three crystal leads through the circuit board. Be sure the crystal is flat against the top of the board; then solder the leads to the foil. Cut off the excess lead lengths.

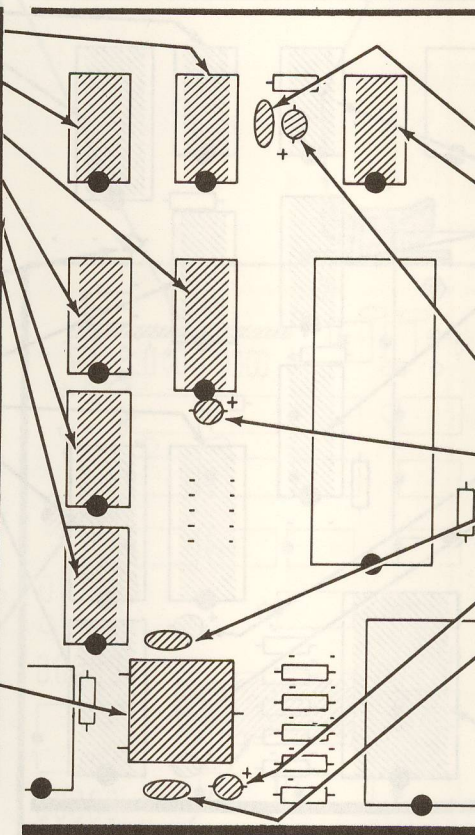

CONTINUE ▾

- () C19: .001 μ F (1000 pF) ceramic.
- () IC11: 74LS08 IC (#443-780).
- NOTE: When you install tantalum capacitors in the next two steps, be sure to match the positive (+) mark or dot on the capacitor to the "+" mark on the circuit board.
- () C13: 2.2 μ F tantalum.
- () C11: 2.2 μ F tantalum.
- () C5: 33 pF ceramic.
- () C17: 2.2 μ F tantalum. Position the positive (+) mark as shown.
- () C6: 33 pF ceramic.
- () Solder the leads to the foil and cut off the excess lead lengths.

PICTORIAL 1-7

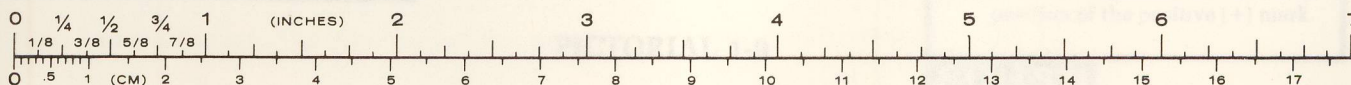

IDENTIFICATION
DRAWING

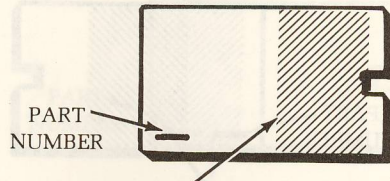

The parts installed in this Pictorial are in this area of the circuit board.

START ↘

NOTE: Be sure that IC leads are perpendicular to the IC cases before you install IC's in this Pictorial.

() IC10: 74LS00 IC (#443-728).

() IC8: 74LS257 IC (#443-802).

() IC6: 74LS157 IC (#443-799).

NOTE: Be sure to match the positive (+) mark or dot with the "+" mark on the circuit board as you mount tantalum capacitors in the next two steps.

() C15: 2.2 μ F tantalum.

() C18: 2.2 μ F tantalum.

() Solder the leads to the foil and cut off the excess lead lengths.

NOTE: Be especially careful as you install the following IC, that all the IC leads are straight before you push the IC into its socket.

() IC5: DM8130 IC (#443-796).

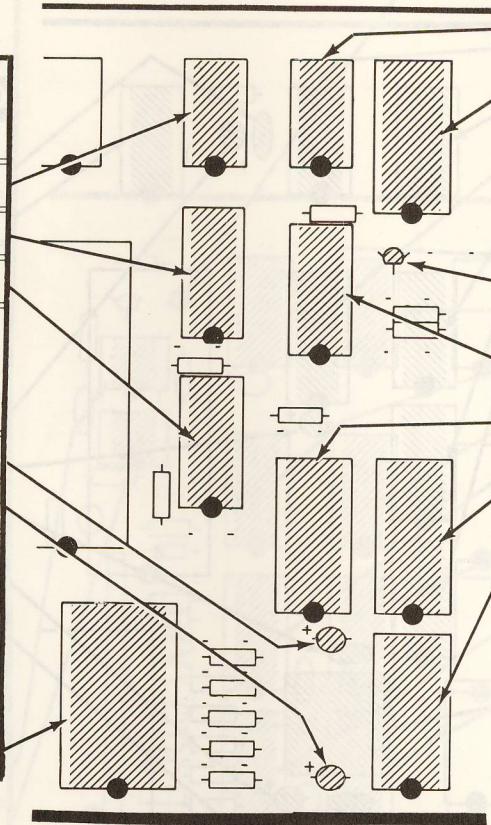

CONTINUE ↙

() IC9: 7438 IC (#443-77).

() IC2: 74LS240 IC (#443-754).

NOTE: When you install the transistor in the following step, be sure to match the flat on the transistor with the outline of the flat on the circuit board.

() Q1: MPSA06 transistor (#417-821). Solder the leads to the foil and cut off the excess lead lengths.

() IC7: 74LS257 IC (#443-802).

() IC3: 74LS240 IC (#443-754).

() IC4: 74S240 IC (#443-753).

() IC1: 74LS240 IC (#443-754).

PICTORIAL 1-8

START →

- () Reposition the circuit board as shown.
- () Push the 25-pin circuit board connector firmly down onto the circuit board as shown. Solder the pins to the foil and cut off the excess pin lengths.

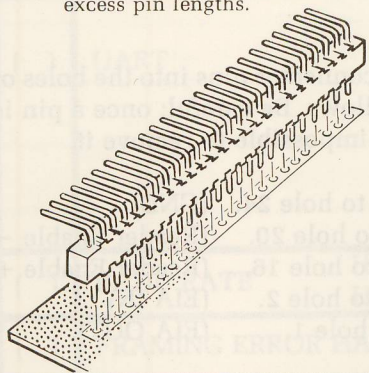

NOTE: The integrated circuit that you install in the next step is a rugged and reliable component. However, normal static electricity discharged from your body through an integrated circuit pin to an object can damage the integrated circuit. Read the entire instruction first. Then carefully perform each step without interruption.

- () IC27: Install a 4702 IC (#443-793) at IC27 as follows:
 1. Remove the IC from its package with both hands.
 2. Hold the IC in one hand, remove the conductive foam, and straighten any bent pins with the other hand.
 3. Roll the IC on a flat surface to make the pins perpendicular to the IC body.
 4. Continue holding the IC, being careful not to touch it to anything while you touch the circuit board with your other hand.
 5. Install the IC in its socket.

- () IC20: IM6402 IC (#443-761). Use the same precautions to handle this IC as you used in the previous step.

IDENTIFICATION DRAWING

PART NUMBER

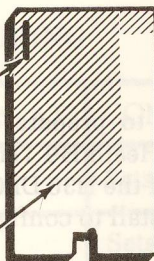

The parts installed in this Pictorial are in this area of the circuit board.

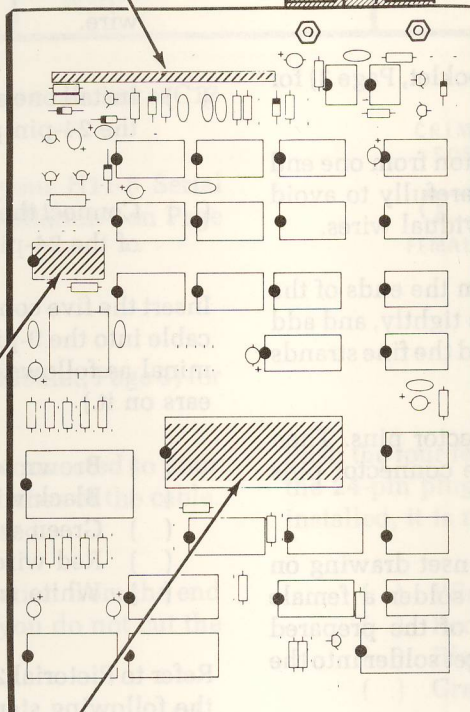

CONTINUE →

- () Position the circuit board puller onto the foil side of the board as shown. Secure the puller with 4-40 × 1/4" screws, #4 lockwashers, and 4-40 nuts. Then carefully peel the backing paper from the Serial I/O label. Press the label onto the center of the circuit board puller as shown.

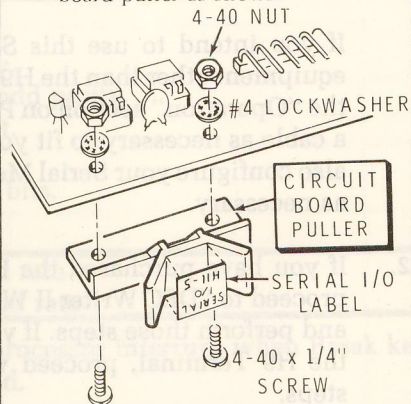

CIRCUIT BOARD CHECKOUT

NOTE: At this time there are several unused circuit board holes. Some of these holes will be used later. Component locations "C12," "R22," and "R24" may be used later. You should have two 1000 Ω resistors (brown-black-red) and a .005 μF ceramic capacitor left over.

Carefully inspect the circuit board for the following most commonly made errors.

- () Unsoldered connections.
- () Poor solder connections.
- () Solder bridges between foil patterns.
- () Protruding leads which could touch together.

Refer to the illustrations where the parts were installed as you make the following visual checks.

- () Transistors for proper **type** and **installation**.
- () Integrated circuits for proper **type** and **installation**.
- () Diodes for proper **type** and correct position of the banded end.
- () Tantalum capacitor for the correct position of the positive (+) mark.

FINISH

Set the circuit board aside temporarily.

PICTORIAL 1-9

CABLE AND CONFIGURATION

NOTES:

- The following steps direct you to prepare a 5-wire cable to be used with the Heath H9 Terminal, how to prepare the cable of the H36 DEC Writer II, and what jumpers to install to configure your Serial Module.

If you intend to use this Serial Module with equipment other than the H9 or H36, proceed to the "Operation" section on Page 27 and prepare a cable as necessary to fit your equipment, and also configure your Serial Module with jumpers as necessary.

- If you have purchased the H36 DEC Writer II, proceed to "DEC Writer II Wiring" (on Page 19) and perform those steps. If you have purchased the H9 Terminal, proceed with the following steps.

H9 Cable and Configuration

Refer to Pictorial 2-1 (Illustration Booklet, Page 3) for the following steps.

- Remove 1-1/2" of outer insulation from one end of the 5-wire cable. Do this carefully to avoid damaging or cutting the individual wires.
- Remove 1/8" of insulation from the ends of the wires, twist the bare wire ends tightly, and add a small amount of solder to hold the fine strands together.
- Locate a strip of female connector pins. Then bend and separate five female connector pins from the strip.
- Refer to Detail 2-1A and the inset drawing on Pictorial 2-1 and crimp and solder a female connector pin onto one end of the prepared white wire. Be careful; do not get solder into the open end of the pin.
- In the same manner, crimp and solder four female pins onto the other four prepared wires at this end of the cable.
- In a similar manner, prepare the remaining end of the cable.

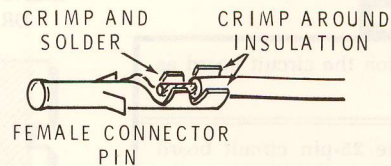

Detail 2-1A

Push the five female connector pins into the holes of the 24-pin plug as follows. Be careful; once a pin is installed, it is nearly impossible to remove it.

- Brown wire to hole 24. (GND)
 - Black wire to hole 20. (Reader Enable -)
 - Green wire to hole 16. (Reader Enable +)
 - White wire to hole 2. (EIA IN)
 - Red wire to hole 1. (EIA OUT)
- Cut a 2-1/2" yellow wire and, as before, crimp and solder a female pin onto each end of the wire.
 - Install one end of the yellow wire into hole 23 of the 24-pin plug.
 - Connect the free end of the yellow wire to hole 3 of the 24-pin plug.

Insert the five connectors at the free end of the 5-wire cable into the 9-pin socket supplied with the H9 Terminal as follows. (The socket may or may not have ears on it.)

- Brown wire to hole 9. (GND)
- Black wire to hole 6. (Reader Enable -)
- Green wire to hole 5. (Reader Enable +)
- Red wire to hole 4. (EIA OUT)
- White wire to hole 1. (EIA IN)

Refer to Pictorial 2-2 (Illustration Booklet, Page 3) for the following steps.

In the following chart, use the cutoff resistor leads you saved earlier. Use them as jumper wires to configure your Serial Module. Solder them to the foil and cut off the excess wire lengths as you install them. Leave the jumpers arched above the board so they do not short out circuit board foils.

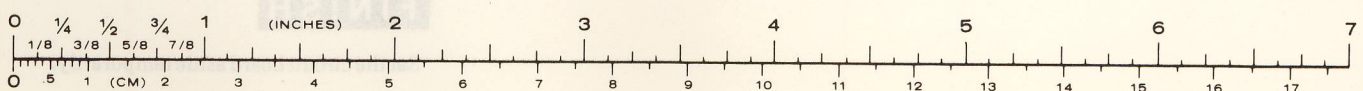

H9/H19 WIRING

	NAME	INSTALL JUMPERS AT:	COMMENTS:
()	ADDRESS	A3 and A7.	Sets device address at 177560 ₈ .
()	VECTOR	V3, V6, and V7.	Sets vector address at 60 ₈ and 64 ₈ .
()	UART	NP (no jumper). EPS (no jumper). TSB for logic 0. NB2 (no jumper). NB1 (no jumper).	No parity. Even or odd parity. 1 stop bit. } 8 data bits.
()	BAUD RATE	H9 H19	FR0 & FR3 FR0, FR1, and FR2
			600 baud rate 9600 baud rate
()	FRAMING ERROR HALT	H1.	Causes processor interrupt when Break key is pressed.
()	EIA ENABLE	W30.	

- () C12: Install the .005 μF ceramic capacitor at C12 (noise filtering).

This completes the assembly of your H11-5 Serial Interface Module. Proceed to "Installation" on Page 25.

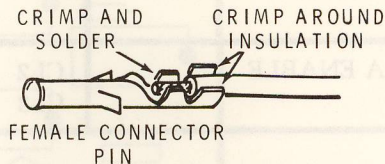

Detail 2-3A

DEC Writer II Wiring

Refer to Pictorial 2-3 (Illustration Booklet, Page 3) for the following steps.

- () At the free end of the cable connected to your DEC Writer II, cut off three inches of the cable. The connector will not be used.
- () Remove 1-1/2" of outer insulation from the end of the cable. Be careful that you do not cut the wires inside.
- () Remove 1/8" of insulation from the ends of the wires, twist the bare wire ends tightly, and add a small amount of solder to hold the fine strands together.
- () Refer to Detail 3-3A and the inset drawing on Pictorial 3-3 and crimp and solder a female connector pin onto each wire. Be careful; do not get solder into the open end of the pin.

Push the four female connector pins into the holes of the 24-pin plug as shown. Be careful; once a pin is installed, it is nearly impossible to remove it.

- () White wire to pin 22. (Receive +)
- () Red wire to pin 19. (Transmit -)
- () Black wire to pin 9. (Receive -)
- () Green wire to pin 8. (Transmit +)

- () Cut a 2-1/2" yellow wire and, as before, crimp and solder a female pin onto each end of the wire.
- () Install one end of the wire into hole 23 and the other end into hole 10.



Refer to Pictorial 2-2 for the following steps.

In the following chart, use the cutoff resistor leads you saved earlier. Use them as jumper wires to configure your Serial Module. Solder them to the foil and cut off the excess wire lengths as you install them. Leave the jumpers arched above the board so they do not short out circuit board foils.

H36 WIRING

	NAME	INSTALL JUMPERS AT:	COMMENTS
()	ADDRESS	A3 and A7.	Sets device address at 177560 ₈ .
()	VECTOR	V3, V6, and V7.	Sets vector address at 60 ₈ and 64 ₈ .
()	UART	NP (no jumper). TSB for logic 0. NB2 (no jumper). NB1 (no jumper).	No parity. 1 stop bit. } 8 data bits.
()	BAUD RATE	FR1.	300 baud rate.
()	FRAMING ERROR HALT	H1.	Causes processor interrupt when Break key is pushed.
()	20 mA ENABLE	CL2 CL3	Receive. Transmit.

- () R22: Install a 1000 Ω resistor (brown-black-red) at R22 (20 mA receive).
- () R24: Install a 1000 Ω resistor (brown-black-red) at R24 (20 mA transmit).
- () C12: Install the .005 μF ceramic capacitor at C12 (noise filtering).

This completes the assembly of your H11-5 Serial Interface Module.

INSTALLATION

Refer to Pictorial 2-4 (Illustration Booklet, Page 4) for the following steps.

- () Refer to Detail 2-4A and position the circuit board as shown. Then plug the 25-wire cable onto the circuit board. Make sure the outside yellow wire is on your left and the outside black wire is on your right.
- () Install the free end of the 25-wire cable in rear panel opening AG of your H11 Computer as shown.

- () Refer to Detail 2-4B (Illustration Booklet, Page 4) and carefully install the Serial Module in slot number 3. Be sure the circuit board fits into the card guides. NOTE: If you intend to use more than one Serial Module in your Computer, refer to your H11 Operation Manual for installation instructions of the additional modules.

NOTE: In the following step, use the label(s) that correspond(s) to the peripheral(s) you intend to use with your Computer.

- () Carefully peel the backing paper from the Printer and/or Console labels. Then press the labels(s) onto the rear of the chassis below the proper Molex connectors.

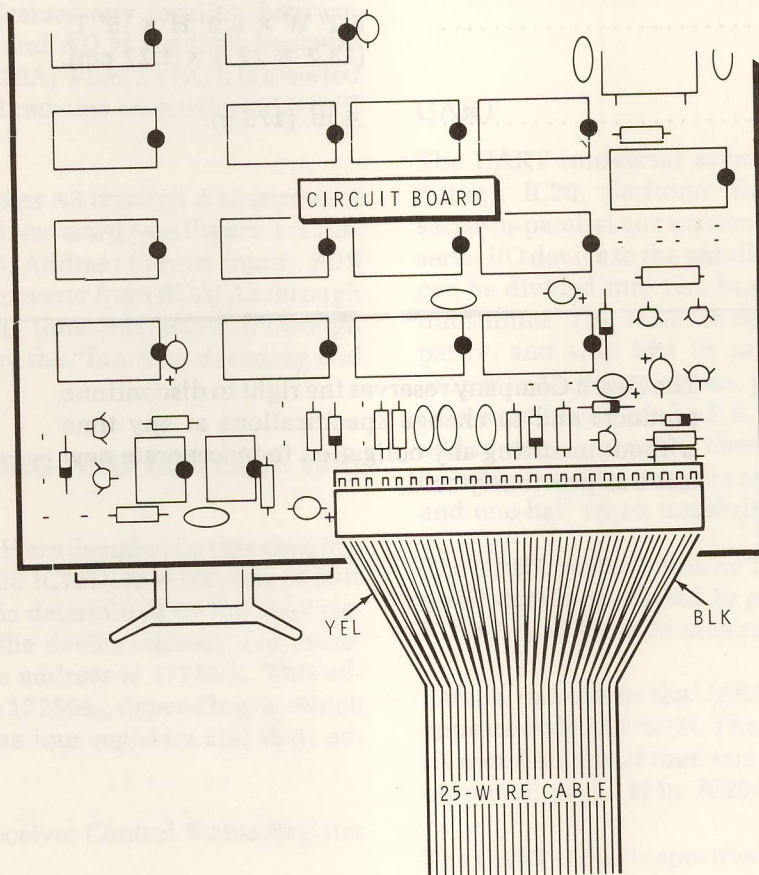

Detail 2-4A

SPECIFICATIONS

Power Requirements	+5 volts; 350 mA typical, 500 mA max. +12 volts; 100 mA typical, 200 mA max.
Output	20 mA current loop (passive or active) or EIA.
Baud Rates	50, 75, 110, 134.5, 150, 200, 300, 600, 1200,
(Crystal-Controlled)	1800, 2400, 4800, or 9600.
Data Word Length	5, 6, 7, or 8 bits. Odd or even parity checking and generation.
Miscellaneous	— Electrically and physically compatible with H11 and PDP 11/03 system. — Control status register (CSR) and data registers compatible with PDP11 software.
Size	5.2" W × 8.9" H × .5" T (13.2 × 22.8 × 1.27 cm).
Weight4 lb. (175 g).

The Heath Company reserves the right to discontinue products and to change specifications at any time without incurring any obligation to incorporate new features previously sold.



CIRCUIT DESCRIPTION

Refer to the Schematic Diagram (on fold-in), Block Diagram (Illustration Booklet, Page 5), and "Glossary of Terms" (Page 26) as you read the following information. (See the H11 Operation Manual for bus timing.)

ADDRESSING

The Serial Module has a unique address that is treated as a memory location by the processor. This address is user programmable by jumpers A3 through A12.

When an address appears on the system bus, it is coupled through bus receivers to IC5 where an EXCLUSIVE-OR operation occurs between the jumpers and the address on the bus. If the address on the bus and the programmed address are equal, AD H is asserted. [BBS 7L (Bank Select 7) is asserted by the processor when it addresses any location between 28k and 32k.]. BS 7H and AD H are then logically ANDed and latched (IC19A) when SYNC L is asserted producing ME H. ME H remains asserted until SYNC L is negated.

Address selection jumpers A3 through A12 represent 10 bits of the 16-bit address word [see Figure 1 (Illustration Booklet, Page 6), Address Format input]. BBS 7L is decoded by the processor from BDAL13 through BDAL15. The remaining three bits, BDAL 0 through BDAL 2, are decoded by the "function decoding and control circuitry."

FUNCTION DECODING AND CONTROL CIRCUITRY

RDAB 1 H and RDAB 2 H are decoded by this circuitry (IC12A, B; IC18B, C; and IC16D) to select one of four registers. The register is determined by the least significant octal digit of the device address. For example, the console device address is 177560₈. This address can be 177560₈ to 177566₈, depending on which register is selected. The four registers and their address are:

- 177560₈ RCSR Receiver Control Status Register
- 177562₈ RBUF Receiver Buffer Register
- 177564₈ XCSR Transmitter Control Status Register
- 177566₈ XBUF Transmitter Buffer Register

Figure 2 (Illustration Booklet, Page 6) shows a listing of these registers and their contents.

RDAB 1 H and RDAB 2 H are latched (IC19C) at address time when SYNC L is asserted. After SYNC L is asserted, a DIN (data into the processor) or a DOUT (data out of the processor) occurs which causes BRPLY L to be asserted after an approximate 150 ns delay. If a DIN occurs, bus drivers (IC4) are enabled and the data selector receives the function select signals which determine which of the registers will be gated to the bus drivers. If a DOUT occurs, the bus drivers remain off; and again the function select signals determine which of the registers will be written into. The registers are various flip-flops and logic circuits on the Serial Module.

UART

The UART (universal asynchronous receiver transmitter), IC20, performs the parallel-to-serial and serial-to-parallel conversions necessary to interface a serial I/O device to the parallel system bus. The UART can be divided into two basic sections; receiver and transmitter. The receiver converts serial start, data, parity, and stop bits to parallel data; and verifies proper code transmissions, parity, and stop bits. The data word length can be 5, 6, 7, or 8 bits. Parity may be odd or even, and parity checking and generation can be inhibited. The stop bits may be one, or two, or one and one-half when transmitting a 5-bit code.

The UART receives data by TTL SD IN H (pin 20). The serial data is converted to parallel data and sent out RD 0-7 H to the data selector.

Parallel data enters the UART by the bus receivers and appears on RDAB 0-7H. The UART stores this data in its own buffer and then converts it to serial data and outputs it as SO H by IC26C.

The UART status is specified by DA H (pin 19), TBMT H (pin 22), and FE H (pin 14). DA H is bit 7 in the RCSR and is asserted when an entire character has been received and is ready for input to the processor.

TBMT H is bit 7 in the XCSR and is asserted when XBUF is empty and can accept another character for

transmission. FE H is connected to BHALT L through an inverter and jumper H1. FE H asserted indicates that the first stop bit was invalid.

DATA SELECTOR

The data selector circuitry (IC6, 7, and 8) gates the appropriate signals to the bus drivers in response to the function select signals and VEC 1 L. Normally VEC 1 L is not asserted. If the RCSR is addressed (DAL 2 H, DAL 1 H not asserted), then the data selector gates the receiver status signals to the bus drivers. If a DIN occurs, then the bus drivers are enabled and the information is presented to the bus.

If RBUF is addressed (DAL 1 H asserted, DAL 2 H not asserted), the data selector gates RD 0-7 H from the UART to the bus drivers. If a DIN occurs, the bus drivers are enabled.

If XCSR is addressed (DAL 2 H asserted, DAL 1 H not asserted), the data selector gates the transmitter status signals to the bus drivers and the assertion of DIN enables the bus drivers.

If XBUF is addressed (DAL 2 H, DAL 1 H asserted), then the data selector is turned off because XBUF is a "write only" register.

If a DOUT occurs during the addressing of any of the above registers, the bus drivers will remain off. The function decoding circuit decodes DOUT and gates the signals from the bus receivers to the register selected. RBUF is the only "read only" register and therefore cannot be written into.

If an interrupt occurs and VEC 1 L is asserted, the data selector gates the vector jumper information to the bus drivers.

INTERRUPT LOGIC

The interrupt logic allows the Serial Module to interrupt the processor. Interrupts may be either receiver or transmitter generated, with receiver generated interrupts having the highest priority.

A receiver-generated interrupt occurs if bit 6 in the RCSR (IC13A) is set (interrupt enabled) and DA H is asserted. Bit 6 in the RCSR is set under program control and latched by IC13A, asserting RD INT EN H. DA H is asserted by the UART when it has received data from the serial I/O device. The combination of DA H and RD INT EN H causes the interrupt logic (IC15A) to assert BIRQ L. The processor responds (if the program status word, bit 7, is not set) by asserting BDIN L. Approximately 150 ns later, BIAKO L is asserted. BIAKO L is received by the serial module from the system bus as BIAKI L. BIAKI L clears IC15A, which negates BIRO L, if the transmitter is not requesting an interrupt. BIAKI L also asserts VEC1 L, which enables the data selector (IC6 and IC7) to gate the vector address to the bus drivers. BRPLY L is asserted approximately 150 ns after the assertion of VEC1 L. When the processor receives BRPLY L and the vector address, it negates BDIN L and BIAKO L. The serial module responds by negating VEC1 and BRPLY L.

Transmitter-generated interrupts operate similar to receiver-generated interrupts. This interrupt occurs if bit 6 in the XCSR (IC13B) is set (interrupt enabled), TBMT H is asserted, and a receiver interrupt is not present. Bit 6 in the XCSR is set under program control and latched by IC13B, asserting TD INT EN H. TBMT H is asserted by the UART when it is ready to accept another character for transmission to the serial I/O device. When a transmitter-generated interrupt is initiated, VEC2 H is asserted by the interrupt logic when the processor asserts BDIN L. Otherwise, the same sequence of signals occurs as when a receiver interrupt is initiated. VEC2 H is gated through the data selector to the bus drivers when VECIL is asserted. This causes the least significant octal digit of the vector address to be 4₈.

The interrupt logic will pass BIAKO L to the system bus if the serial module is not requesting an interrupt. BIAKO L will not pass if the serial module is requesting an interrupt.

The module electrically nearest the processor will be serviced first if more than one module requests an interrupt. This feature allows you to select interrupt priority by physical placement of the modules in the backplane.

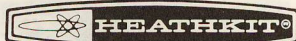

BAUD RATE GENERATOR

The baud rate generator (IC27) is composed of a 2.4576 MHz crystal oscillator and a jumper programmable divider circuit. The jumpers select the divide ratio required to produce the desired baud rate. (See Figure 3.) The CLK L (pin 10) output from the baud rate generator is used by the UART as a clock to determine the proper receive and transmit baud rate.

TRUTH TABLE FOR RATE SELECT INPUTS

FR3	FR2	FR1	FR0	Output Rate (Z)
				Note 1: Jumper removed produces logic 1; jumper installed produces logic 0.
0	0	0	0	Multiplexed Input (I_M)
0	0	0	1	Multiplexed Input (I_M)
0	0	1	0	50 Baud
0	0	1	1	75 Baud
0	1	0	0	134.5 Baud
0	1	0	1	200 Baud
0	1	1	0	600 Baud
0	1	1	1	2400 Baud
1	0	0	0	9600 Baud
1	0	0	1	4800 Baud
1	0	1	0	1800 Baud
1	0	1	1	1200 Baud
1	1	0	0	2400 Baud
1	1	0	1	300 Baud
1	1	1	0	150 Baud
1	1	1	1	110 Baud

Figure 3

READER RUN LOGIC

The reader is under program control by the reader run logic. Bit 0 in the RCSR (IC22A) is set by program control to advance the paper tape reader. Reader enable is latched until a valid start bit is detected. The output at the reader enable terminal will be a pulse with a width that is determined by the baud rate. The same CLK L signal used for the UART is also used for a clock in this circuit.

BREAK LOGIC

Break is enabled by setting bit 0 of XCSR (IC22B) by program control. This is latched by the break logic and must be reset by program control. If break is enabled, a continuous space is transmitted.

-8-VOLT INVERTER

The baud rate generator supplies a 614 kHz square wave signal which drives a transistor inverter circuit. The transistors switch the 12-volt supply which produces an AC voltage that is rectified and filtered to produce -8-volts DC.

GLOSSARY OF TERMS

TERM	DEFINITION	SIGNAL TRUE CONDITION OCCURS WHEN LINE IS:
AD H	Address detect	High
BBS 7L	Bus baud select 7	Low
BDAL 0-15 L	Bus data/address lines	Low
BDIN L	Bus data in	Low
BHALT L	Bus halt	Low
BIAKI L	Bus interrupt acknowledge in	Low
BIAKO L	Bus interrupt acknowledge out	Low
BIRO L	Bus interrupt request	Low
BRPLY L	Bus reply	Low
BS 7H	Bank select 7	High
CLK L	Clock	Low
DA H	Data available	High
DAL 0-15 H	Data address line	High
DIN H	Data in	High
DOUT H	Data out	High
FE H	Framing error	High
ME H	Module enable	High
RDAB 0-7 H	Receive data/address from bus	High
RD 0-7 H	Receive data from UART	High
RD INT EN H	Receiver interrupt enable	High
SO H	Serial output	High
SYNC L	Sync	Low
TBMT H	Transmit buffer empty	High
TD INT EN H	Transmit interrupt enable	High
TTL SD IN H	TTL serial data in	High
VEC1 L	Vector 1	Low
VEC2 H	Vector 2	High

OPERATION

CONFIGURATION

Refer to Pictorial 3-1 (Illustration Booklet, Page 7) for the locations of the 35 jumpers that control the operation of the Serial Interface Module.

Module Address

Jumpers A3 through A12 determine the address of the Serial Interface Module. Only address bits 03 through 12 are programmed by the jumpers, producing the 16-bit Module address.

Jumpers removed produce logic 1.

Jumpers installed produce logic 0.

If this Module services the main console device, the jumper selected address must be 177560_8 .

1. Select the desired octal address of the Serial Module. This address must be between 160000_8 and 177770_8 .
2. Write this octal address in the "Octal Address" boxes provided in Figure 4 (Illustration Booklet, Page 7).
3. Convert the octal address to a binary address and write this number in the "Binary Address" boxes in Figure 4 (Illustration Booklet, Page 7).
4. Install jumpers on the Module at all locations where a logic "0" is called for.

Vector Address

Jumpers V3 through V7 determine the vector address of the Serial Module. Only vector bits 03 through 07 are programmed by jumpers, producing the 16-bit vector address. Refer to Figure 5 (Illustration Booklet, Page 7) and program it the same as you programmed the Module address. If the Module services the main console device, the vector address must be 60_8 .

Jumpers removed produce logic 1.

Jumpers installed produce logic 0.

UART Operation

UART operation is programmed by jumpers NP, TSB, NB2, NB1, and ESP as shown below.

Jumpers removed produce logic 1.

Jumpers installed produce logic 0.

NUMBER OF DATA BITS	NB1	NB2
5	0	0
6	1	0
7	0	1
8	1	1

Number of stop bits transmitted.

TSB logic 0 = One stop bit.

TSB logic 1 = Two stop bits; 1.5 for 5 character format.

Parity transmitted

NP logic 1 = No parity bit.

NP logic 0 and EPS logic 0 = Odd parity.

NP logic 0 and EPS logic 1 = Even parity.

Baud Rate Selection

Baud rate is programmed by jumpers FR0 through FR3. See Figure 3 on Page 25.

Jumpers removed produce logic 1.

Jumpers installed produce logic 0.

EIA Interface

EIA drivers are enabled when jumper W30 is installed. This jumper applies -8 volts to the EIA driver IC. Remove the jumper for 20 mA current loop operation. As shown on Pictorial 2-1 (Illustration Booklet, Page 3), connect the jumper coming from connector hole 23 to hole 3.

20 mA Current Loop Interface

Jumpers CL1 through CL4, and 1000 Ω resistors (brown-black-red) R22 and R24, are associated with 20 mA current loop operation. Remove W30 and remove or install jumpers as desired for the functions listed below.

Active Current Loop

Transmit = R24 installed, CL3 installed, CL4 removed.

Receive = R22 installed, CL2 installed, CL1 removed.

Passive Current Loop

Transmit = R24 removed, CL4 installed, CL3 removed.

Receive = R22 removed, CL1 installed, CL2 removed.

If the Module is operated in the passive current loop mode, the device that supplies the current must limit the current to 20 mA.

Connect the jumper coming from connector hole 23 to hole 10.

For teletype (TTY) operation, install capacitor C12 (.005 μF ceramic) for debouncing. NOTE: If desired, you may install C12 for baud rates of 600 and less.

Framing Error Halt

A framing error halt allows entry to console microcode directly from the console device by pressing the "break" key; and thus producing a framing error. A framing error occurs when the received character

has no valid stop bit. This error condition is detected by the UART. Installation of jumper H1 causes the assertion of BHALT L when the framing error is detected. The processor then executes console microcode. Install this jumper if the Module is to service the main console device.

REAR PANEL CONNECTOR

PIN	PURPOSE
1	EIA Transmit Data L
2	EIA Data Receive
3	EIA TTL Receive Data
4	Carrier
5	Clear to Send H
6	Jumper only for EIA RS 232
7	Data Set Ready H
8	20 mA Transmit (+)
9	20 mA Receive (-)
10	TTL Receive Data H
11	
12	
13	
14	
15	Jumper only for 20 mA current loop
16	Reader Enable (+)
17	RQST Send H
18	Data Term Ready H
19	20 mA Transmit (-)
20	Reader Enable (-)
21	Busy H
22	20 mA Receive (+)
23	TTL SD IN H
24	GND

SEMICONDUCTOR IDENTIFICATION CHARTS

DIODES

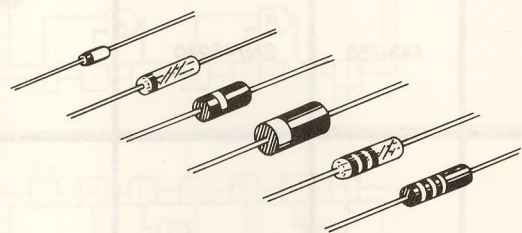
COMPONENT	HEATH NUMBER	MAY BE REPLACED BY	IDENTIFICATION
D1, D2, D3, D5, D6	56-56	1N4149	
ZD4	56-621	1N4738A	

TRANSISTORS

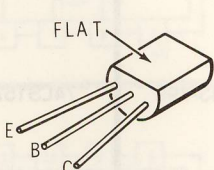
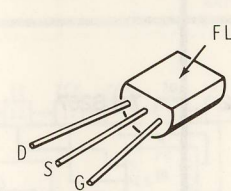
COMPONENT	HEATH NUMBER	MAY BE REPLACED BY	IDENTIFICATION
Q1, Q4, Q5	417-821	MPSA06	
Q2, Q6, Q7	417-865	MPSA55	
Q3	417-897	30V 1 mA FET (SELECTED)	

INTEGRATED CIRCUITS

COMPONENT	HEATH NUMBER	MAY BE REPLACED BY	IDENTIFICATION
IC1, IC2, IC3	443-754	SN74LS240	
IC4	443-753	SN74S240	
IC5	443-796	DM8130	
IC6	443-799	74LS157	
IC7, IC8	443-802	74LS257	

Integrated Circuits (cont'd.)

COMPONENT	HEATH NUMBER	MAY BE REPLACED BY	IDENTIFICATION
IC9	443-77	7438	
IC10, IC16	443-728	SN74LS00N	
IC11, IC26	443-780	74LS08	
IC12	443-800	74LS27	
IC13, IC15, IC17, IC22	443-730	SN74LS74N	

Integrated Circuits (cont'd.)

COMPONENT	HEATH NUMBER	MAY BE REPLACED BY	IDENTIFICATION
IC14, IC18	443-797	74LS10	
IC19	443-781	74LS75	
IC20	443-761	IM6402	
IC21	443-779	74LS02	
IC23	443-795	75189 OR 1489	

Integrated Circuits (cont'd.)

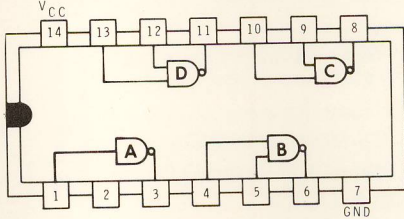
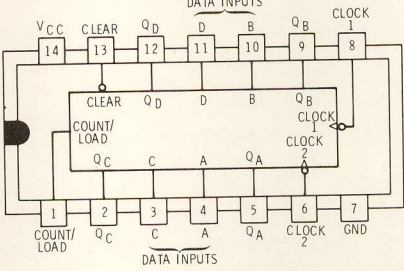
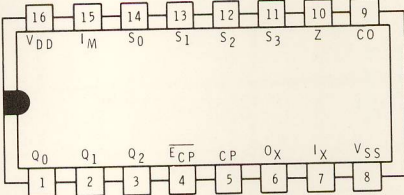
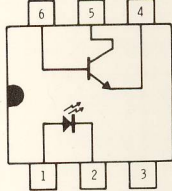
COMPONENT	HEATH NUMBER	MAY BE REPLACED BY	IDENTIFICATION
IC24	443-794	75188 OR 1488	
IC25	443-801	74LS196	
IC27	443-793	4702	
IC28, IC29	443-808	4N26	

FOR PARTS REQUESTS ONLY

- Be sure to follow instructions carefully.
- Use a separate letter for all correspondence.
- Please allow 10 - 14 days for mail delivery time.

DO NOT WRITE IN THIS SPACE

INSTRUCTIONS

- Please print all information requested.
- Be sure you list the correct **HEATH** part number exactly as it appears in the parts list.
- If you wish to prepay your order, mail this card and your payment in an envelope. Be sure to include 10% (25¢ minimum, \$3.50 maximum) for insurance, shipping and handling. Michigan residents add 4% tax.
Total enclosed \$ _____
- If you prefer COD shipment, check the COD box and mail this form. COD

NAME _____
 ADDRESS _____
 CITY _____
 STATE _____ ZIP _____

The information requested in the next two lines is not required when purchasing nonwarranty replacement parts, but it can help us provide you with better products in the future.

Model # _____ Invoice # _____
 Date _____ Location _____
 Purchased _____ Purchased _____

LIST HEATH PART NUMBER	QTY.	PRICE EACH	TOTAL PRICE

TOTAL FOR PARTS	
HANDLING AND SHIPPING	
MICHIGAN RESIDENTS ADD 4% TAX	
TOTAL AMOUNT OF ORDER	

SEND TO: **HEATH COMPANY**
 BENTON HARBOR
 MICHIGAN 49022
ATTN: PARTS REPLACEMENT

Phone (Replacement parts only): 616 982-3571

THIS FORM IS FOR U.S. CUSTOMERS ONLY
 OVERSEAS CUSTOMERS SEE YOUR DISTRIBUTOR

FOR PARTS REQUESTS ONLY

- Be sure to follow instructions carefully.
- Use a separate letter for all correspondence.
- Please allow 10 - 14 days for mail delivery time.

DO NOT WRITE IN THIS SPACE

INSTRUCTIONS

- Please print all information requested.
- Be sure you list the correct **HEATH** part number exactly as it appears in the parts list.
- If you wish to prepay your order, mail this card and your payment in an envelope. Be sure to include 10% (25¢ minimum, \$3.50 maximum) for insurance, shipping and handling. Michigan residents add 4% tax.
Total enclosed \$ _____
- If you prefer COD shipment, check the COD box and mail this form. COD

NAME _____
 ADDRESS _____
 CITY _____
 STATE _____ ZIP _____

The information requested in the next two lines is not required when purchasing nonwarranty replacement parts, but it can help us provide you with better products in the future.

Model # _____ Invoice # _____
 Date _____ Location _____
 Purchased _____ Purchased _____

LIST HEATH PART NUMBER	QTY.	PRICE EACH	TOTAL PRICE

TOTAL FOR PARTS	
HANDLING AND SHIPPING	
MICHIGAN RESIDENTS ADD 4% TAX	
TOTAL AMOUNT OF ORDER	

SEND TO: **HEATH COMPANY**
 BENTON HARBOR
 MICHIGAN 49022
ATTN: PARTS REPLACEMENT

Phone (Replacement parts only): 616 982-3571

THIS FORM IS FOR U.S. CUSTOMERS ONLY
 OVERSEAS CUSTOMERS SEE YOUR DISTRIBUTOR

CUT ALONG DOTTED LINE

ILLUSTRATION BOOKLET

Part of 595-2037-03

PARTS PICTORIAL

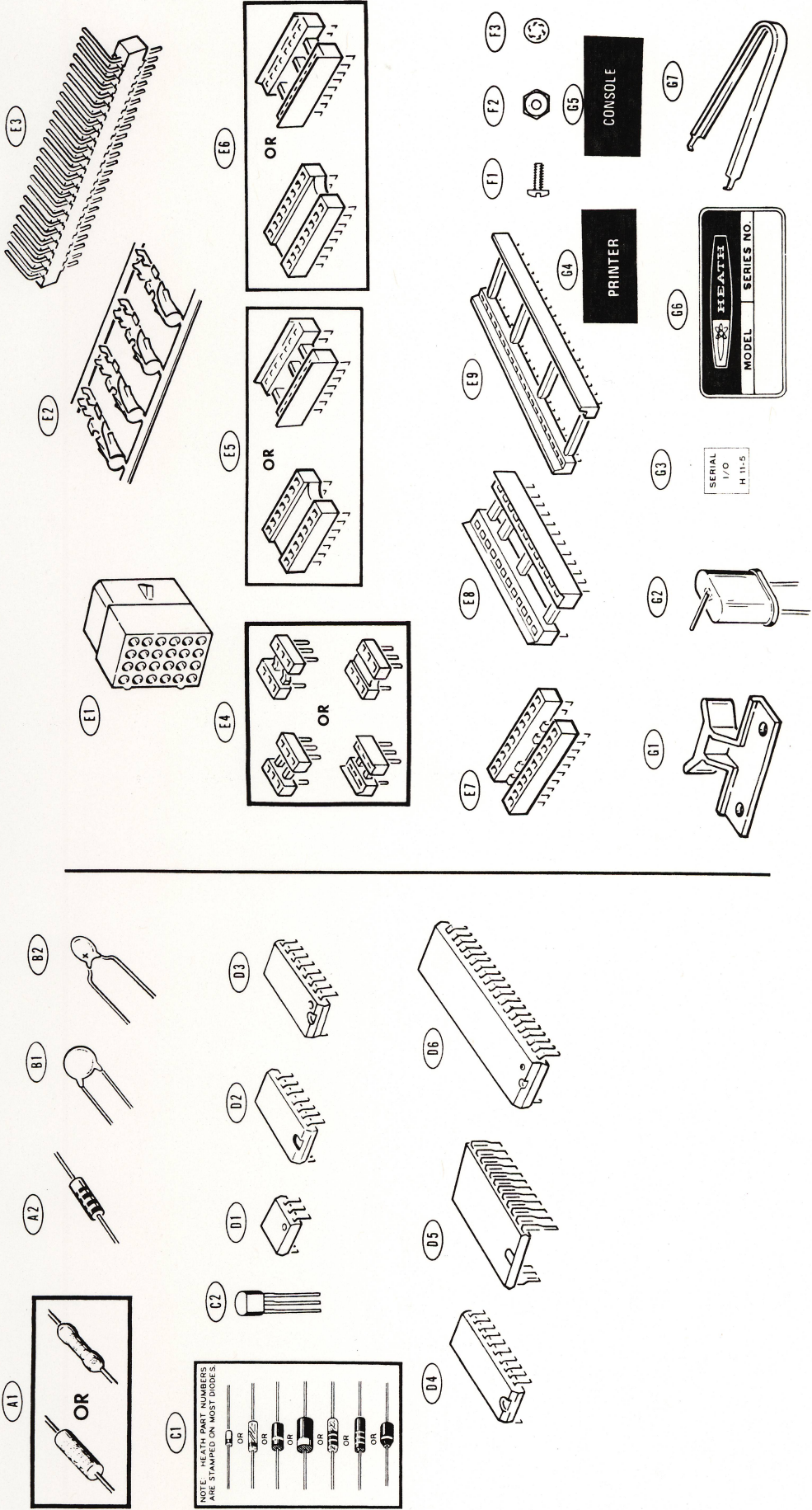

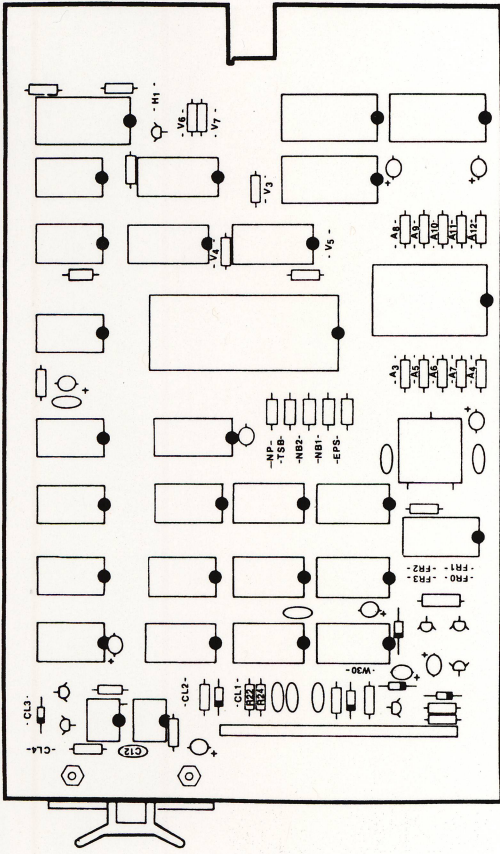

PICTORIAL 2-2

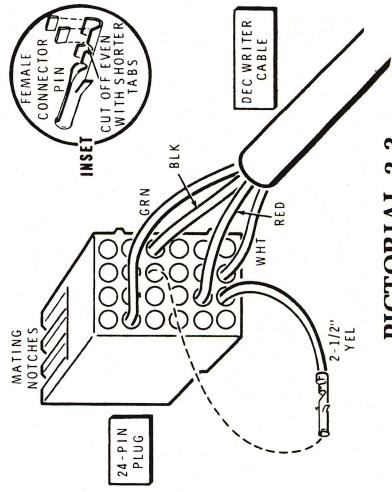

PICTORIAL 2-3

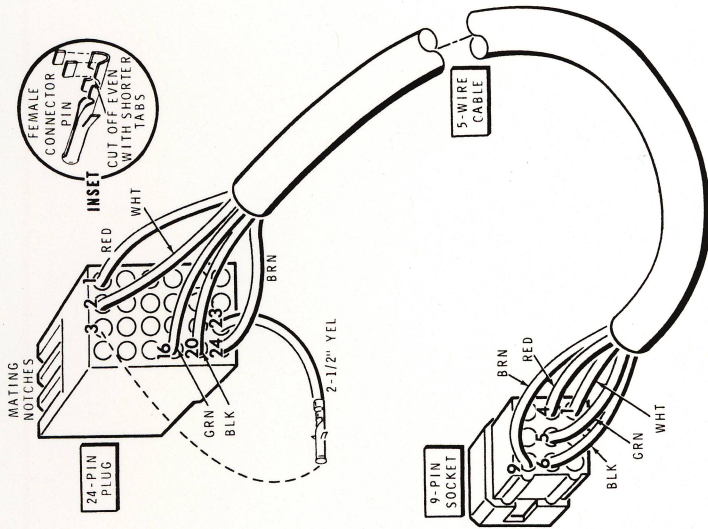

PICTORIAL 2-1

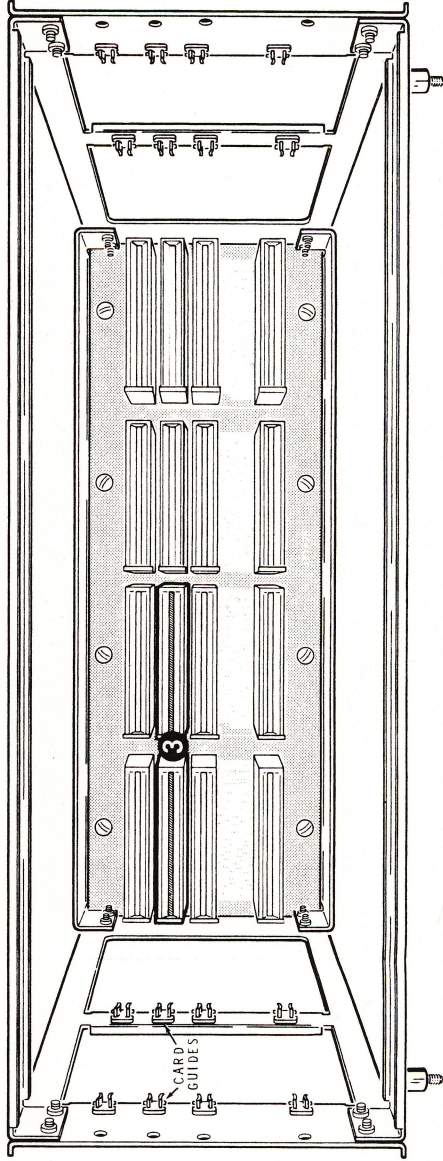
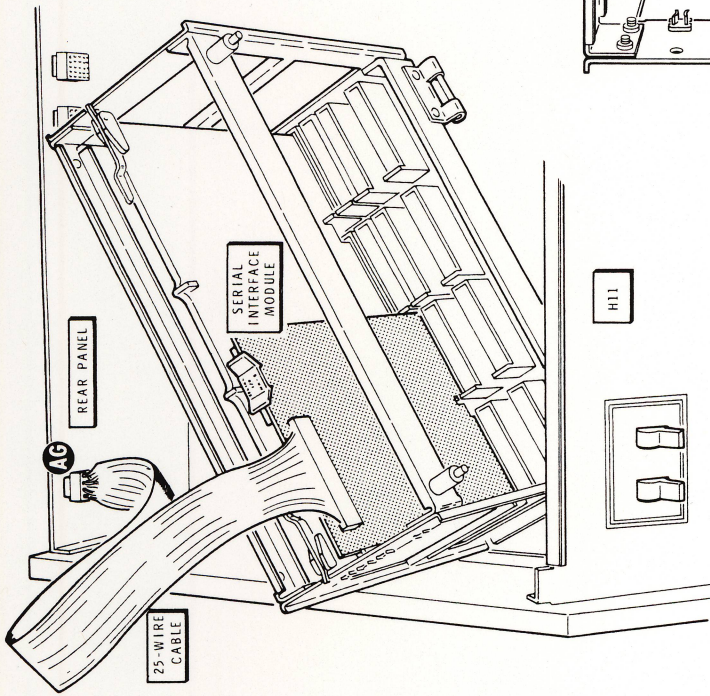

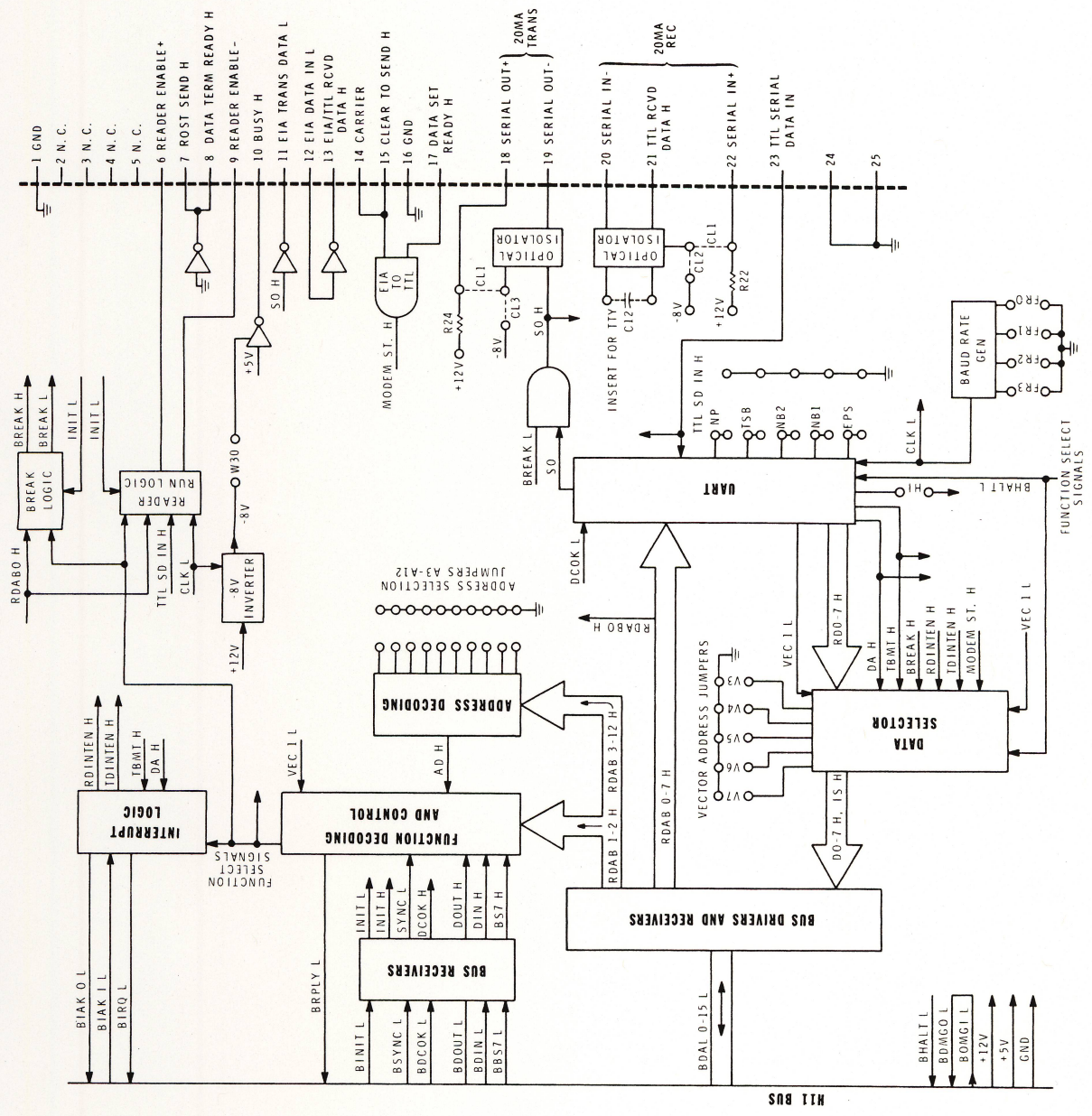

BLOCK DIAGRAM

M11 BUS

H11 - SLU

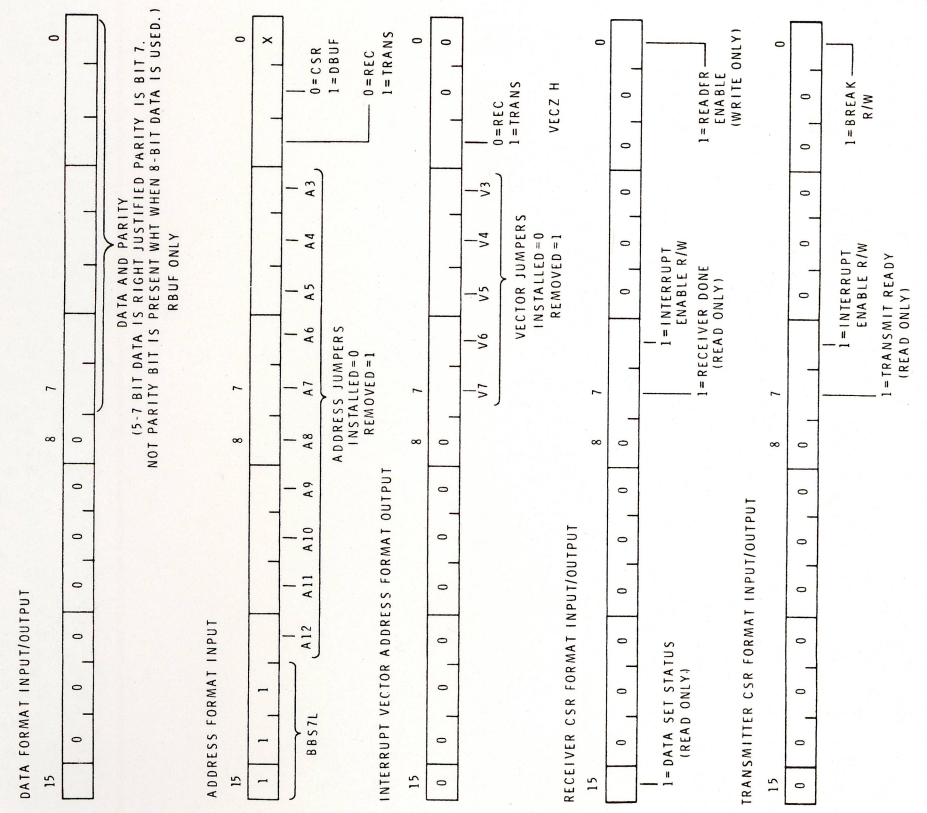
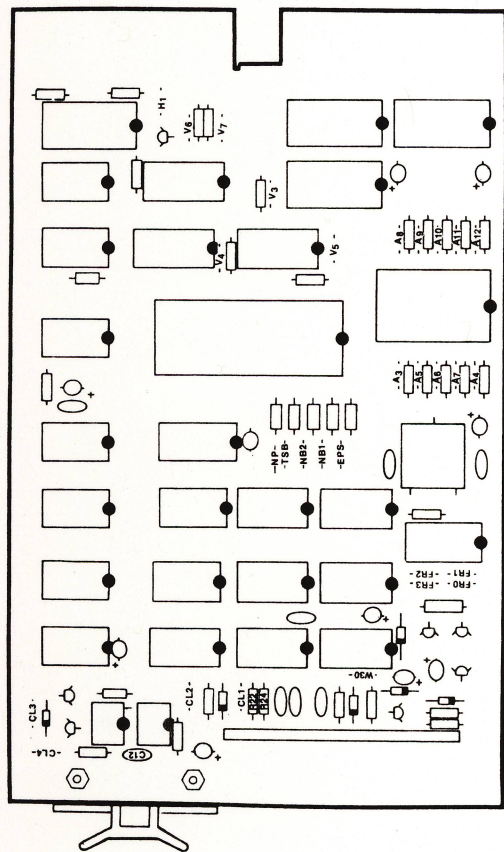

Figure 1

Word	Bit(s)	Function
RCSR	15	Dataset Status—Set when CARRIER or CLEAR TO SEND and DATA SET READY signals are asserted by an EIA device. Read-only bit.
	14—08 07	Not used. Read as 0. Receiver Done—Set when an entire character has been received and is ready for input to the processor. This bit is automatically cleared when RBUF is addressed or when the BDCOK H signal goes false (low). A receiver interrupt is enabled by the H11-5 when this bit is set and receiver interrupt is enabled (bit 6 is also set). Read-only bit.
	06	Interrupt Enable—Set under program control when it is desired to generate a receiver interrupt request when a character is ready for input to the processor (bit 7 is set). Cleared under program control or by the BINIT signal. Read/write bit.
	05—01 00	Not used. Read as 0. Reader Enable—Set by program control to advance the paper tape reader on a teletypewriter device to input a new character. Automatically cleared by the new character's start bit. Write-only bit.
RBUF	15—08	Not used. Read as 0.
	07—00	Contains five to eight data bits in a right-justified format. MSB is the optional parity bit. Read-only bit.
XCSCR	15—08	Not used. Read as 0.
	07	Transmit Ready—Set when XBUF is empty and can accept another character for transmission. It is also set during the power-up sequence by the BDCOK H signal. Automatically cleared when XBUF is loaded. When transmitter interrupt is enabled (bit 6 also set), an interrupt request is asserted by the H11-5 when this bit is set. Read-only bit.
	06	Interrupt Enable—Set under program control when it is desired to generate a transmitter interrupt request when the H11-5 is ready to accept a character for transmission. Reset under program control or by the BINIT signal. Read/write bit.
	05—01 00	Not used. Read as 0. Break—Set or reset under program control. When set, a continuous space level is transmitted. BINIT resets this bit. Read/write bit.
XBUF	15—08	Not used.
	07—00	Contains five to eight right-justified data bits. Loaded under program control for serial transmission to a device. Write only.

Figure 2



PICTORIAL 3-1

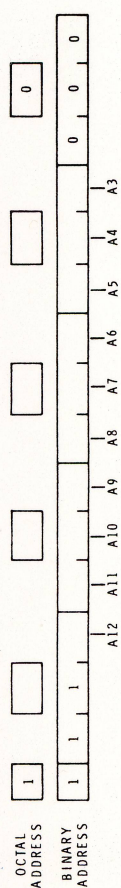

Figure 4

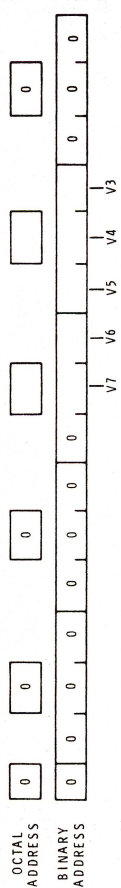
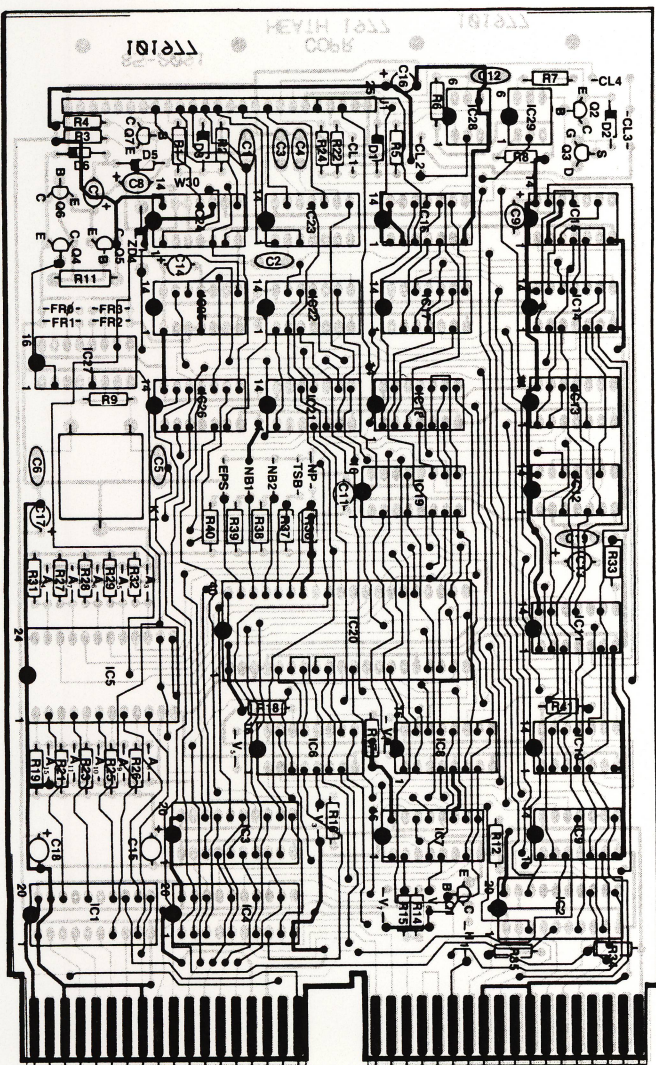

Figure 5

CIRCUIT BOARD X-RAY VIEWS

NOTE: To find the PART NUMBER of a component for the purpose of ordering a replacement part:

- A. Find the circuit component number (R5, C3, etc.) on the X-Ray View.
- B. Locate this same number in the "Circuit Component Number" column of the "Parts List" in the front of this Manual.
- C. Adjacent to the circuit component number, you will find the PART NUMBER and DESCRIPTION which must be supplied when you order a replacement part.



(Shown from component side, component side foil shown in red)

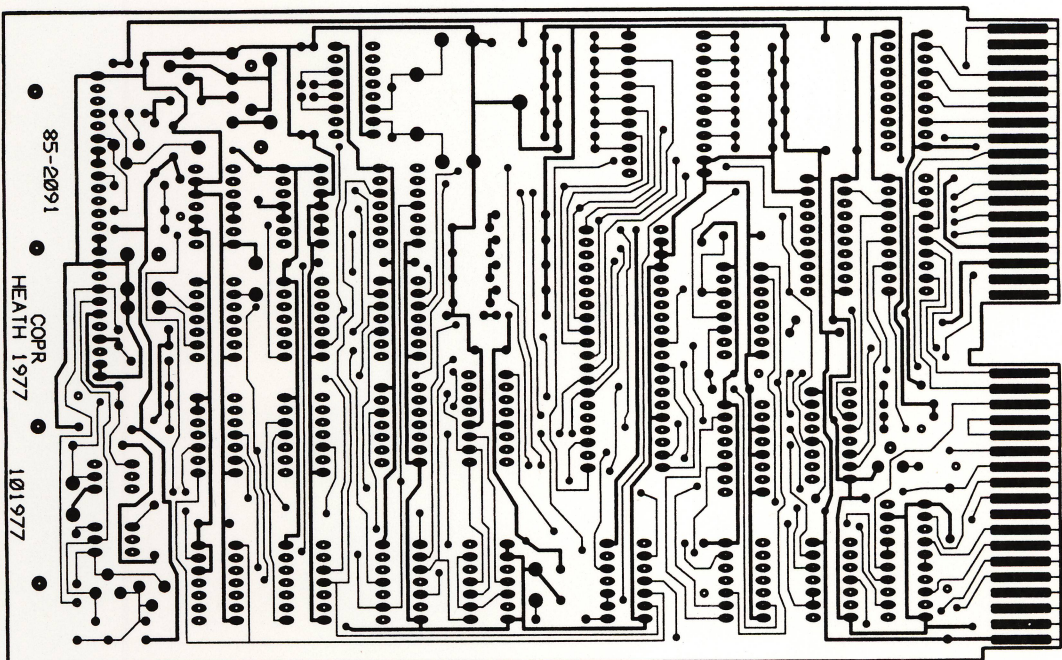

85-2091
 COPR
 HEALTH 1977
 101977

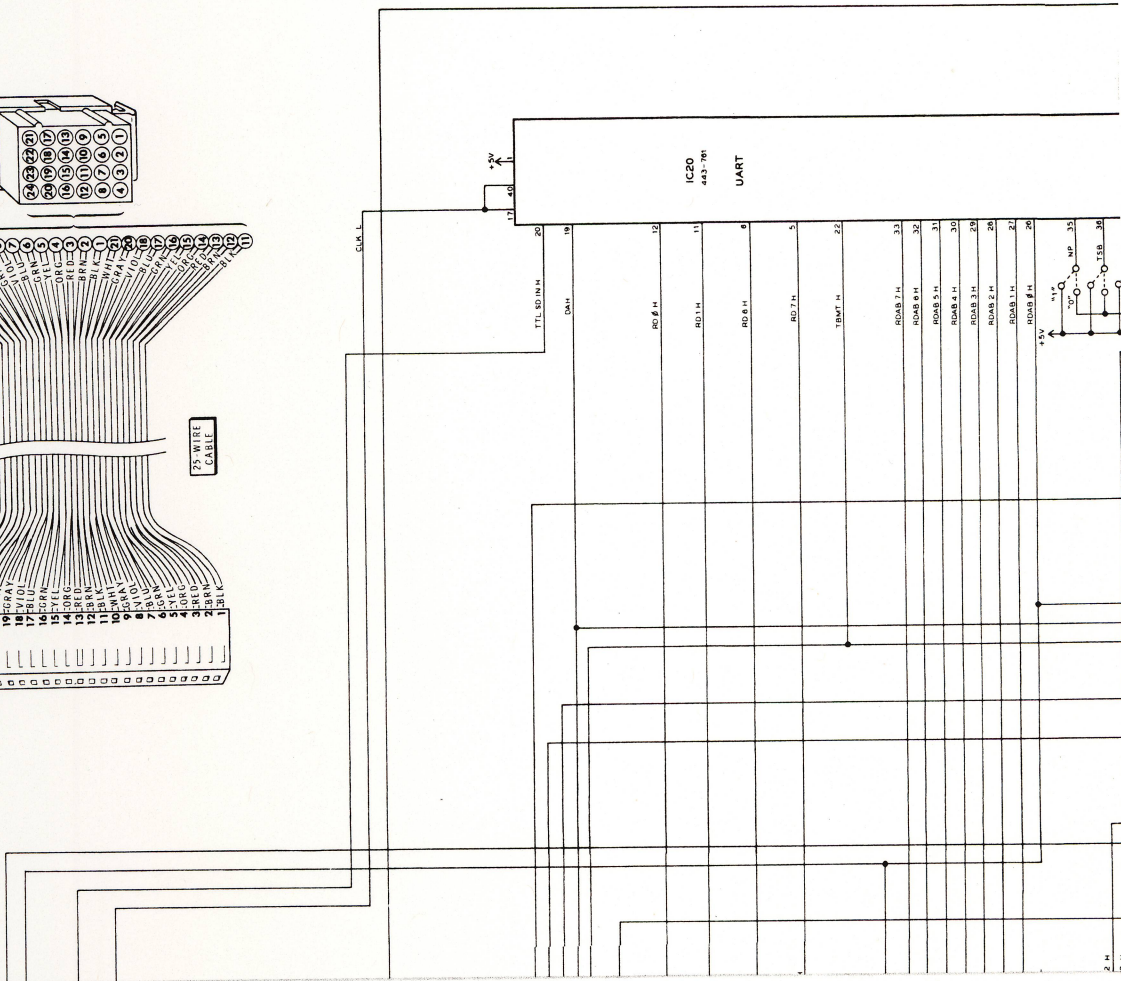
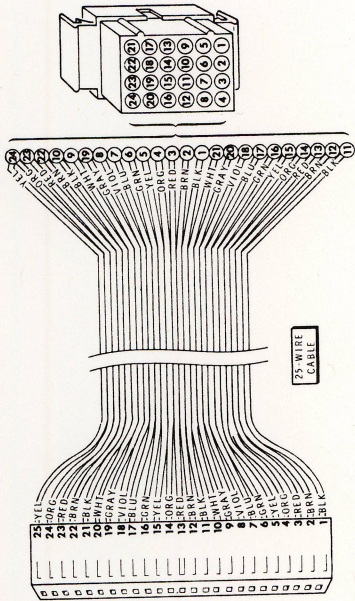

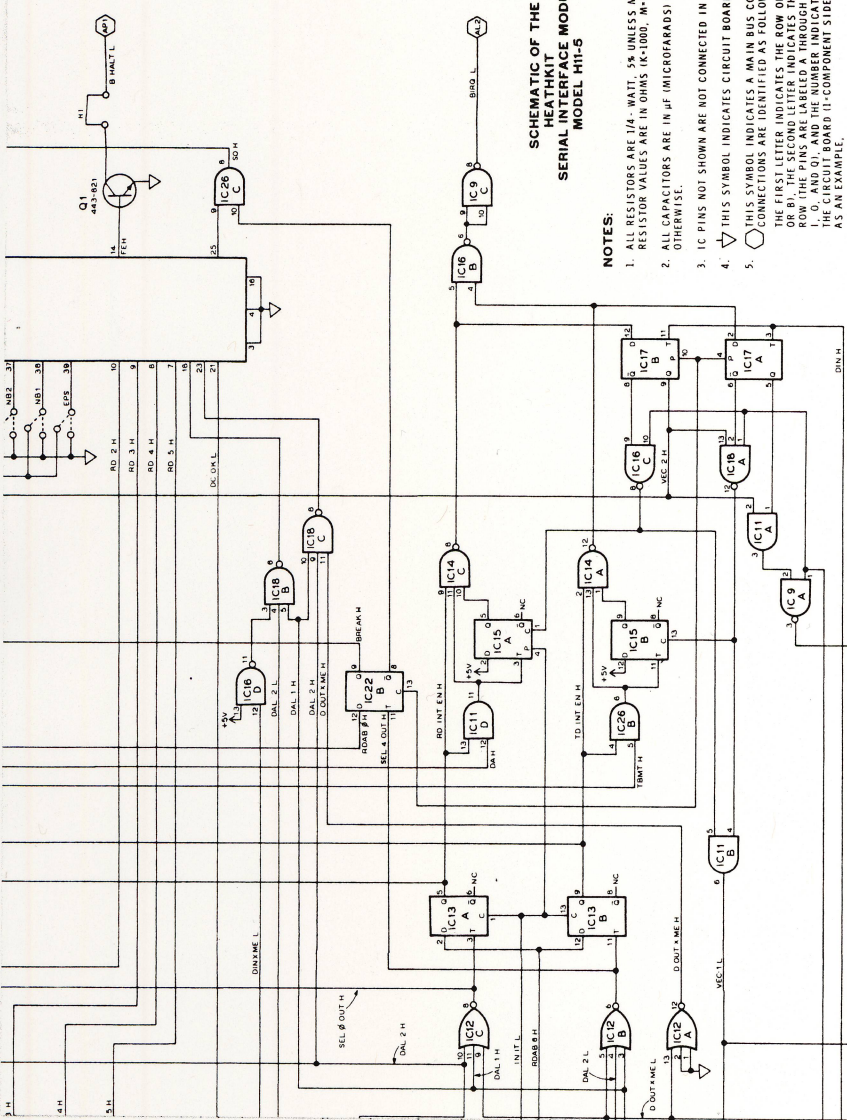

**SCHEMATIC OF THE
HEATHKIT LOGIC STRIP MODULE
MODEL M13-3**

NOTES:

1. ALL RESISTORS ARE 1/4 WATT, 5% UNLESS MARKED OTHERWISE. RESISTOR VALUES ARE IN OHMS (K=1000, M=1,000,000).
2. ALL CAPACITORS ARE IN μ F (MICROFARADS) UNLESS MARKED OTHERWISE.
3. IC PINS NOT SHOWN ARE NOT CONNECTED IN THE CIRCUITS.
4. ∇ THIS SYMBOL INDICATES CIRCUIT BOARD GROUND.
5. \circ CONNECTIONS ARE IDENTIFIED AS FOLLOWS:
THE FIRST LETTER INDICATES THE ROW OF PINS (EITHER A OR B), THE SECOND LETTER INDICATES THE PIN OF THAT ROW (A, B, C, D), AND THE NUMBER INDICATES THE SIDE OF THE CIRCUIT BOARD (1=COMPONENT SIDE; 2= SOLDER SIDE).

CUSTOMER: PLEASE PLACE THIS SCHEMATIC IN YOUR COMPUTER'S OPERATION MANUAL.

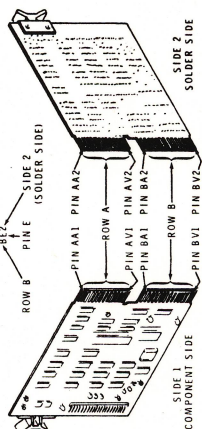

Copyright © 1977
Heath Company
All Rights Reserved
Printed in the United States of America

Part of 5895-2037

